

GREENHOUSE OPERATION AND MANAGEMENT



PAUL V. NELSON

Student Reference

Greenhouse Operation and Management

Writers:

Patricia DeFacio, Lynn Pickerel, Susan M. Rhyne
Instructional Materials Laboratory
University of Missouri-Columbia

Susan M. Rhyne, Editor
Instructional Materials Laboratory
University of Missouri-Columbia

Produced by
Instructional Materials Laboratory
10 London Hall
University of Missouri-Columbia
Columbia, MO 65211

Volume 34
Number 2

Catalog Number
10-2010-S

1st edition: January 1990
Revised edition: June 2002

Available from
Instructional Materials Laboratory
University of Missouri-Columbia
2316 Industrial Drive
Columbia, MO 65202
573-882-2883
800-669-2465

©2002 Curators of the University of Missouri. All rights reserved.

The activity that is the subject of this report was supported in whole or in part by funds from the Department of Elementary and Secondary Education, Division of Vocational and Adult Education. However, the opinions expressed therein do not necessarily reflect the position or policies of the Missouri Department of Elementary and Secondary Education or the Division of Vocational and Adult Education, and no official endorsement should be inferred.

Acknowledgments

Funding for the revised edition of *Greenhouse Operation and Management* was made possible through a grant from the Missouri Department of Elementary and Secondary Education.

Thanks are extended to the following advisory committee members for their dedication in developing the outline and reviewing the text: Nancy Alford, Chris Bucheit, Randy Commons, Mary Ann Gowdy, Ken Hoemann, Jonathan Hoer, Jeanne Holmes, Jill Huntsman, Alice Longfellow, Keith Thompson, and Dave Wehmeyer.

Special recognition is extended to Marlowe Schlegel, Deputy State Statistician, Missouri Agricultural Statistics Service, for providing documentation on horticultural specialties.

Appreciation is also expressed to the following staff members of the Instructional Materials Laboratory for their efforts in producing this material: Dana Tannehill, Director; Richard Branton, Assistant Director; Erica Kassel, Senior Coordinator; Chris Benedict, Graphic Designer; Chris Colwell, Computer Specialist; Jessica Meyer, Editorial Assistant; and Becca Scott, Editorial Assistant.

Instructional Materials Laboratory
University of Missouri-Columbia

Foreword

The revised edition of *Greenhouse Operation and Management* is designed as a semester course for 11th and 12th grade students who are interested in various aspects of greenhouse production. The curriculum comprises seven units that reflect relevant issues of concern to a greenhouse owner: (1) The Greenhouse Industry, (2) Growing Structures, (3) Plant Science Basics, (4) Plant Growth, (5) Plant Propagation, (6) Plant Health, and (7) Greenhouse Business Management.

The Student Reference provides a glossary of technical terminology used in greenhouse operations.

Dr. Terry Heiman, Director
Agricultural Education
Missouri Department of Elementary and Secondary Education

Greenhouse Operation and Management

Table of Contents

Acknowledgments..... iii

Foreword..... iv

Unit I: The Greenhouse Industry

Lesson 1: Scope and Development of the Greenhouse Industry1

- Areas of Horticulture
- History of the Greenhouse Industry
- Advancements in the Greenhouse Industry
- Economic Importance of Greenhouse Industry

Lesson 2: Career Opportunities in the Greenhouse Industry7

- Responsibilities of Grower, Retailer, and Wholesaler
- Career Opportunities
- Organizational Structure of a Greenhouse Operation
- Continuing Education
- Agricultural Education Opportunities

Unit II: The Growing Structure

Lesson 1: Greenhouse Parts, Structures, and Coverings.....13

- Site Selection
- Types of Greenhouse Structures
- Construction of a Growing Structure
- Interior Parts of a Greenhouse
- Other Structures and Areas in Commercial Greenhouse Operations

Lesson 2: Environmental Control21

- Types of Environmental Controls
- Monitoring and Controlling Temperature
- Keeping a Greenhouse Warm During Cold Weather
- Ventilating Greenhouses
- Cooling Greenhouses During Warm Weather
- Controlling Greenhouse Humidity
- Irrigation Equipment
- Controlling Carbon Dioxide
- Controlling Light Levels

Lesson 3: Energy Conservation and Environmental Protection	27
Greenhouse Modifications and Procedures Used to Conserve Energy	
Greenhouse Modifications and Procedures Used to Protect the Environment	

Unit III: Plant Science Basics

Lesson 1: Plant Parts, Structures, and Functions	29
Structure of a Plant Cell	
Differences Between Monocots and Dicots	
Specialized Plant Tissues	
Parts and Functions of Seeds	
Functions and Types of Roots	
Functions, Structures, and Types of Stems	
Functions, Structures, and Types of Leaves	
Functions, Parts, and Types of Flowers	
Monoecious vs. Dioecious Plants	
Lesson 2: Plant Processes	41
Photosynthesis	
Respiration	
Absorption	
Translocation	
Transpiration	
Lesson 3: Plant Classification and Nomenclature	45
Plant Characteristics	
Plant Purpose	
Scientific System of Classification and Naming	

Unit IV: Plant Growth

Lesson 1: Environmental Effects	49
Light in the Greenhouse	
Light Intensity	
Light Duration	
Light Quality	
Temperature	
Gaseous Elements	
Lesson 2: Growing Media and Containers.....	55
Importance of Growing Media	
Pasteurizing Field Soil	
Advantages of Soilless Growing Medium	
Ingredients in Soilless Mixes and Soil Amendments	
Selecting Growing Containers	

Basic Types of Containers	
Common Materials for Growing Containers	
Lesson 3: Irrigation	63
Irrigating Greenhouse Crops	
Frequency of Crop Irrigation	
Basic Guidelines for Irrigation	
Delivering Water to Plants	
Lesson 4: Nutrients	69
Effect of Nutrients on Plant Growth	
Essential Nutrients for Plant Growth	
Identifying Nutritional Deficiencies	
Macronutrient Disorders	
Micronutrient Disorders	
Factors Affecting the Availability of Nutrients	
Lesson 5: Fertilizer	75
Fertilizer Management Plan	
Fertilizer Sources	
Available Forms of Fertilizer	
Fertilizer Analysis	
Calculating the Amount of Fertilizer	
Applying Fertilizer	
Unit V: Plant Propagation	
Lesson 1: Sexual Propagation.....	79
Sexual Propagation	
Environmental Conditions for Seed Germination	
Dormancy	
Germination Process	
Steps for Planting Seeds	
Differences in Germinating Monocots and Dicots	
Caring for Seedlings After Germination	
Transplanting Seedlings	
Caring for Seedlings After Transplanting	
Lesson 2: Asexual Propagation.....	83
Asexual Propagation	
General Considerations for Asexual Propagation	
Methods of Asexual Propagation	

Unit VI: Plant Health

Lesson 1: Greenhouse Pests and Diseases	89
Descriptions of Pests	
Effects of Insects and Mites	
Effects of Other Pests	
Causes and Sources of Disease	
Common Diseases	
Lesson 2: Pest Control	95
Pest Control Basics	
Biological Pest Management	
Chemical Pest Management	
Cultural Pest Management	
Mechanical Pest Management	
Integrated Pest Management	
Lesson 3: Pesticide Use and Safety	99
Pesticide Label	
Pesticide Toxicity Levels	
Forms of Pesticides	
Application Methods	
Modes of Action for Pesticides	
Pesticide Safety Issues	
General Pesticide Storage and Disposal Procedures	
Personal Protection Measures	
Handling Accidental Pesticide Poisoning	
Sources of Pesticide Information and Recommendations	
Certifications Required to Use Pesticides	

Unit VII: Greenhouse Business Management

Lesson 1: Commercial Business Crops.....	107
Selecting Commercial Crops	
Determining Growing Schedule	
Analyzing Expenses	
Evaluating the Commercial Crop	
Caring for Commercial Plants After Harvest and During Marketing	
Lesson 2: Marketing Plan	113
Identifying Customers	
Attracting Customers	
Keeping Records	
Glossary	117

UNIT I: THE GREENHOUSE INDUSTRY

Lesson I: Scope and Development of the Greenhouse Industry

This unit examines the greenhouse industry from two broad perspectives: its growth and development and its various career opportunities. Lesson 1 defines the four areas of horticulture and then traces the historical progress of the greenhouse industry. It addresses developments in the industry and examines the economic importance of greenhouse-grown cultivation in Missouri, the United States, and in several countries throughout the world.

Areas of Horticulture

The term “horticulture” was originally derived from the words “garden” and “cultivate.” The word has evolved to mean “the cultivation of plants.” Horticulture is made up of four areas. Floriculture is the cultivation of flowers (cut flowers, bedding plants, foliage plants, and potted plants). Olericulture entails growing vegetables. Ornamental horticulture involves growing plants solely for their beauty (annuals, perennials, shrubs, ground cover, landscaping). (Floriculture is actually an aspect of ornamental horticulture, but it is considered here as a separate field because greenhouses typically focus on producing flowers.) The last area is pomology - growing fruit and nuts.

History of the Greenhouse Industry

Cultivating various types of plants is an age-old custom. Humanity’s connection with plants began in ancient Greece with Theophrastus (377-288 BC) who had a keen interest in the natural world. His investigations resulted in discovering that plant roots absorb nutrients. Without actually knowing their scientific names, he discerned the differences between monocotyledons and dicotyledons (discussed in Unit III, Lesson 1). He also experimented with pruning roots and thereby

concluded that this procedure encouraged flowering and fruit development.

Centuries later during the Roman Empire, Varro (116-20 BC) adapted Theophrastus’ insights and discovered that using legumes in the soil improves its quality. He demonstrated that fruit could be stored after harvest when placed in straw and stored in a cool place. In 77 AD, Dioscorides wrote *De Materia Medica* in which he described roots, stems, leaves, and flowers in great detail. This was considered the authoritative text on plant science for the next 1,500 years.

Greenhouses, however, did not appear until 30 AD, thanks to Roman emperor Tiberius whose doctor prescribed that he eat one cucumber daily. Although glass was not even invented at that time, Tiberius’ gardeners could grow cucumbers out of season by placing the seeds in large pots and covering them with sheets of mica, a transparent mineral. This rudimentary form of a greenhouse was known as a specularium.

By the 13th century, interest in plant growth took an unfortunate turn when a Dominican monk, Albertus Magnus, was charged with witchcraft for tampering with the natural order by trying to force blooms out of season.

The first working greenhouse was built in 1599 in Holland. Throughout Europe, fascination with exotic fruit (oranges, pineapples, and dates) prompted further interest in constructing more hothouses that could nurture such delicacies. During the 17th century, the French built “orangeries” to cultivate the newly exported treat, oranges. At the French palace Versailles, a huge orangery was built that was 500 feet long, 42 feet wide, and 45 feet high. Its southern exposure flooded the growing plants with heat and light.

Greenhouse Operation and Management

In 1737, wealthy Bostonian, Andrew Faneuil, built the first U.S. greenhouse, mostly to cultivate fruit. Many years later, George Washington, who loved pineapples, built a “pinery” at Mt. Vernon. But it was during the 19th century in England that production of greenhouses expanded most fully. Glass was then easily available for constructing these buildings, which were exclusively owned by the wealthy. By 1825, greenhouses were common.

During the 1950s, improvements in transportation allowed growers to reach broader markets. New building materials became available. In 1960, greenhouses were made from film plastic and galvanized steel. Noteworthy botanical greenhouses were built during that decade: the Missouri Botanical Garden (1960), Hamburg Botanic Gardens (Germany, 1963), and the Exhibition Plant Houses at Edinburgh (Scotland, 1967). By 1980, floriculturists in the Netherlands became renowned for concentrating on specific or related crops, relying on automated production, and selling crops by the auction market system.

Advancements in the Greenhouse Industry

Significant technological advancements within the greenhouse industry have occurred recently. Upgraded growing structures, new coverings, and state-of-the-art equipment enable greenhouse owners to increase production, which translates into higher profits. Advancements in growing methods promote healthier, abundant crops. Developments in plant varieties contribute new colors, forms, and resistance to disease. Scientists engaged in biotechnology have produced dramatic results in improving plant production through genetic engineering. Thanks to biotechnological research, consumers can anticipate purchasing improved fruits and vegetables. See Table 1.1.

Greenhouse Operation and Management

Table 1.1 - Improvements in Fruits and Vegetables Through Biotechnology

Fruit or Vegetable	Improvement
Bananas	Resistant to fungus
Garlic	Increased capacity to lower cholesterol
Melons	Smaller, seedless; single-serving size
Peanuts	Improved balance of protein
Peas	Remain sweeter; higher crop yields
Strawberries	Increased levels of natural acids that fight cancer
Tomatoes	Higher levels of cancer-fighting antioxidants

Economic Importance of the Greenhouse Industry

Because the greenhouse industry relies on a workforce and provides products that consumers use, its economic impact is felt locally, nationally, and globally. In 1999, Missouri floriculturists grossing \$10,000 or more contributed \$41.6 million to the state's economy. Floriculture growers grossing \$100,000 or more earned approximately \$34.3 million. Table 1.2 lists the specific crops included in this amount.

Table 1.2 - 1999 Missouri Floriculture Crops

Crop	Wholesale Value
Cut Flowers	\$ 281,000
Foliage Plants	2,192,000
Potted Flowering Plants	11,711,000
Bedding and Garden Plants	20,085,000
TOTAL	\$34,269,000

Compared to the rest of the nation in horticultural production (including sales from greenhouse operations, nurseries, landscaping outlets, and other dealers), Missouri ranks as follows:

- 26th - Floriculture
- 28th - Ornamental horticulture
- 28th - Pomology
- 31st - Commercial vegetables

In the United States, the 2000 wholesale value of floriculture producers grossing \$100,000 or more was nearly \$4.7 billion (including the value of propagative materials). See Figure 1.1.

Figure 1.1 - 2000 U.S. Floriculture Crops

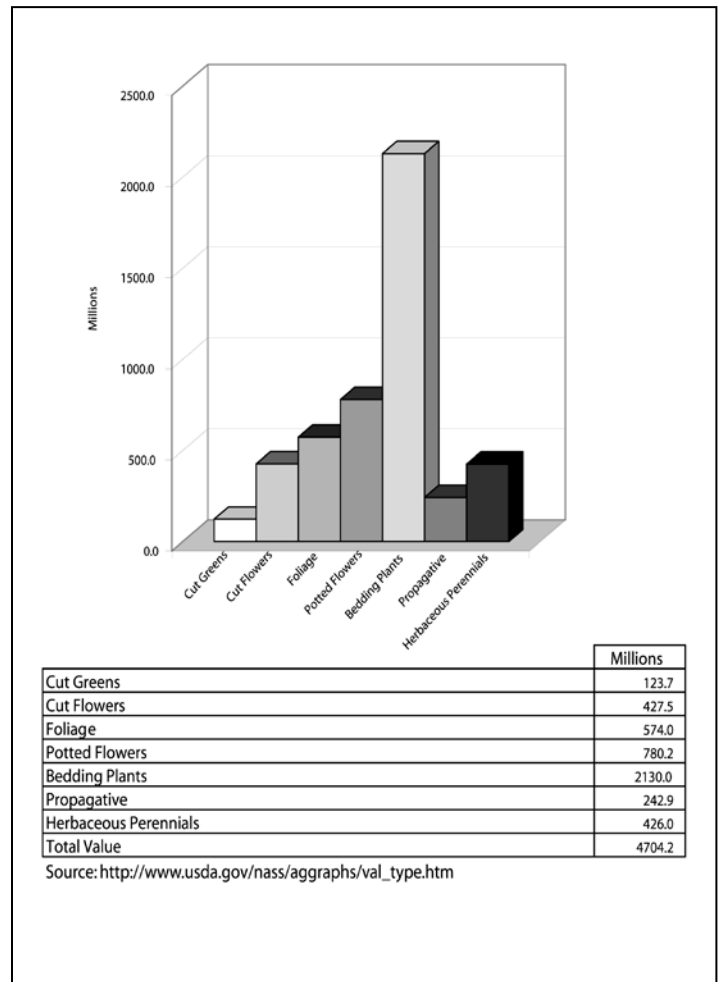

Greenhouse Operation and Management

Five states contributing the most to that amount are California (20%), Florida (18%), Michigan, Texas, and Ohio. In Texas, nursery and greenhouse industries are the second highest agricultural enterprise.

Half of the wholesale value of all reported crops comes from *bedding and garden plants* production. States contributing the most to this crop sector are California, Michigan, Texas, Ohio, and Florida. This segment is made up of potted bedding and garden plants, bedding and garden flats, and flowering hanging baskets. The percentages of these three crops are indicated in Figure 1.2.

Figure 1.2 - 2000 U.S. Bedding and Garden Plant Sector

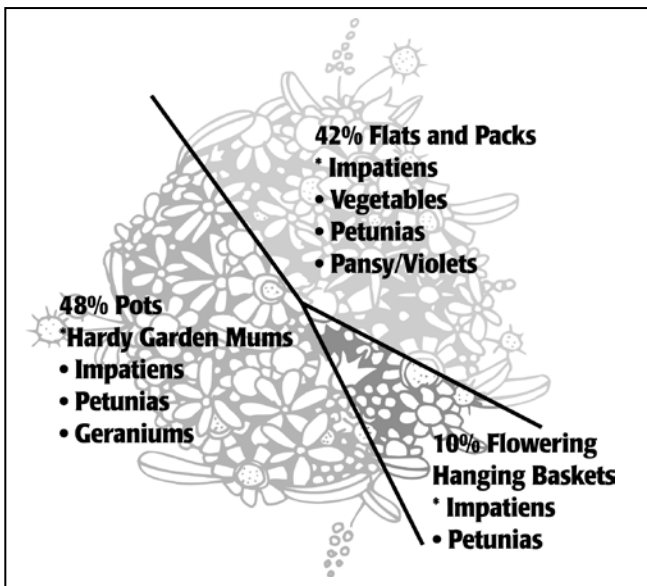

Cultivation of *potted flowering plants* increased 3% from 1999. California was the predominant producer, contributing 18% of total sales. Top sellers were poinsettias, orchids, azaleas, and chrysanthemums.

Foliage plant production increased by 12% from 1999, with Florida capturing 69% of the total market. Within this market sector, 85% of total sales were for potted foliage plants.

However, in 1999, *cut flowers* suffered a 1% decrease in production and a 23% decline in the number of growers nationwide. Providing 67% of the total value for cut flowers, California dominated this market. Favorite flowers in this crop are roses, lilies, and gladioli.

In the *herbaceous perennials* group, 25% of the total production is hardy garden mums. *Propagative materials* are used to grow various types of plants; annual bedding and garden plants accounted for 44% of this market. There was a 2% decrease in production of *cut greens* from 1999. Florida contributed 81% to this market.

The floriculture market throughout the world provides income, employment, and marketing opportunities. The *Netherlands* exports tulip flowers and bulbs and is the international leader in floriculture enterprises. But bulbs exported from the Netherlands are not a direct threat to the U.S. economy because they are sold here and generate income.

In *Central and South America* (Mexico, Costa Rica, Colombia, and Brazil) the climate is favorable, which facilitates simple greenhouse construction. Several government-sponsored subsidies are available that help the greenhouse owner. There is plentiful access to a labor force. Cut flowers (e.g., roses and carnations), flower seeds, and foliage plants are cultivated in these countries.

Kenya has been involved in floriculture since the early 1970s. It produces mainly flowers (especially roses) and seeds for geraniums, petunias, and impatiens. Because of the climate, greenhouses require no supplementary heat. Labor is cheap and abundant. *Australia* and *New Zealand* produce orchids.

Summary

The greenhouse industry comprises four horticultural areas: floriculture, olericulture, ornamental horticulture, and pomology. Of these four areas, the floriculture market typically is the most prevalent, but any of the others also can contribute to the greenhouse industry. Spanning centuries, interest has developed in growing plants. The greenhouse industry has benefited from technological advancements over time and its future is bright. Thanks to improvements in building materials and equipment, greenhouse operations have become more sophisticated. And because of the contributions of plant scientists who are researching biotechnological enhancements in fruit and vegetables, the consumer can anticipate more nutritious and higher quality food in the future. The greenhouse industry sustains a significant portion of the economy of Missouri, the United States, and several countries around the world.

Credits

Biondo, Ronald J. and Dianne A. Noland. *Floriculture: From Greenhouse Production to Floral Design*. Danville, IL: Interstate Publishers, Inc. 2000.

Boodley, James W. *The Commercial Greenhouse*, 2nd ed. Albany, NY: Delmar Publishers, 1996.

Clark, David G. "Floriculture Biotechnology." <<http://hort.ifas.ufl.edu/people/clark.htm>> accessed 2/20/02.

"Floriculture." Missouri Agricultural Statistics Service. *Missouri Farm Facts*, 2000.

"Floriculture Crops." USDA National Agricultural Statistical Service <http://www.usda.gov/nass/aggraphs/ws_tenyr.htm> accessed 2/20/02.

"Floriculture Crops 2000 Summary." USDA National Agricultural Statistics Service, Agricultural Statistics Board, April 2001. <<http://usda.mannlib.cornell.edu/reports/nassr/other/zfc-bb/>> accessed 2/21/02.

Giacomelli, Gene A. "Controlled Environment Agricultural Center." Agricultural & Biosystems Engineering Department, University of Arizona. <<http://ag.arizona.edu/ceac/research/archive/structures.htm#glazings>> accessed 2/25/02.

Greenhouse Operation and Management (Student Reference). University of Missouri-Columbia: Instructional Materials Laboratory, 1990.

"A History of Greenhouses." <http://www.ildkids.com/documents/history_greenhouse.html> accessed 2/19/02.

"History of Greenhouses." Idaho Freedom. <<http://www.idahofreedom.com/construction/gh1001.html>> accessed 2/19/02.

Lee, Jasper S., Series Editor. *Introduction to Horticulture: Science and Technology*, 2nd ed. Danville, IL: Interstate Publishers, Inc., 1997.

Phytotronics, Inc. <<http://www.phytotronics.com/new.htm>> accessed 2/20/02.

"Plant Pathology." New York State Agricultural Experiment Station. Cornell University, Geneva, NY. <<http://www.nysaes.cornell.edu/pp/>> accessed 2/20/02.

Schnelle, Michael A. and John M. Dole. "Greenhouse Structures and Coverings." Oklahoma Cooperative Extension Service OSU Extension Facts F-6700. <<http://www.agweb.okstate.edu/pearl/hort/greenhouses/f6700.htm>> accessed 2/25/02.

USDA National Agricultural Statistics Service. *1997 Census of Agriculture - Census of*

Greenhouse Operation and Management

Horticultural Specialties (1998) Volume 3,
Special Studies, Part 2.

“Value of Sales at Wholesale.” USDA National
Agricultural Statistics Service
<[http://www.usda.gov/nass/aggraphs/val_type.
htm](http://www.usda.gov/nass/aggraphs/val_type.htm)> accessed 2/20/02.

“What Is Horticulture?”
<[http://www.missouri.edu/~jortds/hom0ehort/
intro.html](http://www.missouri.edu/~jortds/hom0ehort/intro.html)> accessed 1/15/02.

UNIT I: THE GREENHOUSE INDUSTRY

Lesson 2: Career Opportunities in the Greenhouse Industry

This lesson first differentiates among the responsibilities of the grower (producer), wholesaler, and retailer; each offers potential employment. Lesson 2 then describes specific duties of various types of greenhouse workers, which may suggest career paths of interest. This lesson also explains the management structures of small and large greenhouse operations, which may help the job seeker. Also described are reasons for continuing education and for participating in agricultural educational opportunities, such as Supervised Agricultural Experience (SAE) activities.

Responsibilities of Grower, Retailer, and Wholesaler

Before selecting a career in the greenhouse industry, it is important to understand its basic elements: growers (producers), retailers, and wholesalers. The focus and tasks of each of these sectors vary and reflect different career opportunities. Growers cultivate one or more crops for sale to the wholesaler. Growers are skilled in cultivation, irrigation, and other cultural practices. In small operations, growers usually delegate marketing responsibilities to the wholesaler. Retailers sell greenhouse crops directly to the public and may also raise some of the plants. Because they deal with consumers, retailers have to be located in accessible marketing areas: grocery stores, florist shops, malls, etc. Wholesalers sell crops and related products directly to retailers and often sell plants from growers on consignment.

Career Opportunities

Successfully running a greenhouse depends upon effective coordination of specialized skills and consistent effort. The number of employees and

career opportunities varies depending upon the scope of the operation. If the greenhouse is fairly large, several types of jobs are required. Employees in large operations can investigate diverse careers, which are described here and are intended to be generic. Actual greenhouse operations may use different job titles, descriptions, and duties.

As an entry-level position, the assistant grower helps the grower perform tasks as assigned. This may involve working with the maintenance crew, shipping and delivering plants, or aiding with various cultural practices. The grower's responsibilities are multifaceted. Among his or her tasks are preparing the growing medium for bulbs, seeds, and cuttings; grafting plants; and transplanting seedlings and rooted cuttings. The grower also ensures that crops are irrigated as required. An important feature of the grower's job is to fertilize plants according to specific needs. Some growers are authorized to apply pesticides as well. Occasionally, he or she responds to customers' questions about caring for their plants.

The greenhouse service technician maintains all of the greenhouse's physical facilities and supervises the maintenance crew. Among the technician's duties are overseeing the mechanical integrity of the irrigation, electrical, and drainage systems. If any construction work is needed to repair or build greenhouse structures, the technician is in charge.

The greenhouse operation relies on the production specialist to stay up-to-date on technical developments that affect plant cultivation. Understanding plant science is critical to this career. The specialist schedules when to plant different crops and manages space allocation

Greenhouse Operation and Management

within the greenhouse, which contributes to crop yield.

Another position within the greenhouse operation is the marketing manager who oversees sales operations of the mature crops. Major responsibilities include customer relations, which involves contacting existing clients and seeking potential patrons, and postharvest crop assessment (grading and storing plants and flowers). The marketing manager also prepares each crop for shipment.

Ultimately, the success of a greenhouse operation depends on the vision and expertise of the owner/manager. This individual is responsible for organizing and prioritizing the flow of work, maintaining financial records, and developing the marketing plan. The owner selects the types and quantities of plants to grow and selects and orders growing supplies (fertilizer, seeds, etc.). It is this individual's responsibility to hire, supervise, and evaluate the staff. In addition, the owner may also respond to customers' questions.

Organizational Structure of a Greenhouse Operation

Just like workers in other businesses, employees in the greenhouse industry are part of an overall organizational structure. Understanding the management structure and knowing one's position within the "chain of command" are conducive to making informed career decisions.

In small greenhouse operations, one owner/manager oversees all aspects of the business, although there may be several assistants. The owner specializes in all greenhouse operations. In large greenhouse operations, the owner may be the manager or a board of directors. Multiple greenhouse specialists contribute to different aspects of the operation. Each department (e.g., marketing, maintenance, plant production) has its own manager and group of employees. The

interrelationships among various facets of a large greenhouse operation are displayed in Figure 1.3.

Figure 1.3 - Organizational Structure of a Large Greenhouse Operation

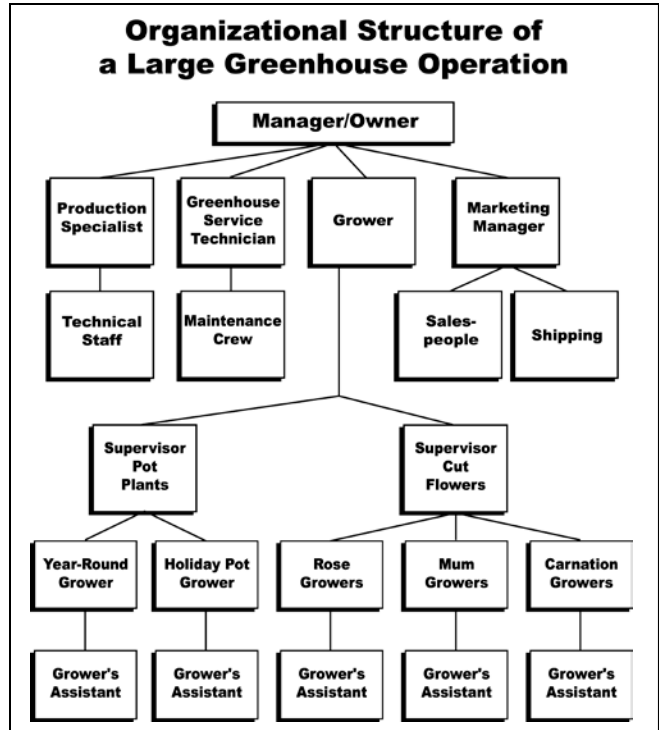

Continuing Education

To progress within the greenhouse industry, whether in wholesale, retail, or a specific job as described above, additional training and education pave the way. There are several avenues for acquiring knowledge and expertise. By reading professional literature, such as greenhouse-related journals, publications from university Extensions, documents from county services, etc., the greenhouse employee can gain valuable insights. Becoming a member of a greenhouse-related organization and attending its meetings create a network of colleagues and a source of up-to-date information. It is also important to remain current on all technological advances in the greenhouse industry by interacting with coworkers, supervisors, and greenhouse specialists. If an interest develops in a highly specialized area,

taking advanced courses for a degree or enrichment fosters success.

Agricultural Education Opportunities

The greenhouse industry offers a variety of opportunities for agricultural education programs. Workplace readiness skills evolve as students develop successful work habits and job-related proficiency. Individuals accept responsibility and establish a solid work ethic, which means being prompt, communicating clearly and honestly, cooperating with coworkers and supervisor, and taking pride in one's work. By working in greenhouse operations, students can gain skills in record keeping, critical thinking, and decision making.

Working in the greenhouse industry also offers the opportunity for hands-on, real-world experience through on-the-job training. Management skills and job-seeking aptitude increase. It is also possible to earn a salary while learning. Especially meaningful is having guidance from individuals who are experienced in greenhouse operations.

Supervised Agricultural Experience (SAE) programs offer unique occasions for personal growth. In the entrepreneurship program, students run their own business. They plan and organize all aspects of an enterprise and are financially responsible for the operation. This means that they own all necessary materials needed to run the enterprise and keep financial records in order to assess how well their investment is performing. In entrepreneurial projects sponsored by GrowNative! (www.conservation.state.mo.us/programs/grownative), individuals or chapters grow plugs or produce seeds of native plants. Examples of entrepreneurial programs include growing bedding plants in school greenhouse for sale and raising poinsettias for sale.

In the placement program, students are placed in an agricultural business that interests them (e.g.,

wholesale greenhouse). This can be a paid position or an unpaid internship. The placement program occurs outside of regular school hours. Examples include working in a florist shop or for a nursery on weekends.

In a directed work experience students, instructors, and parents help plan an activity that meets the interests of the student. This is an unpaid position. An example is working in the school's greenhouse.

Agriscience research projects offer great opportunities for those interested in researching how things work. There are two types of programs available: experimental and analytical. An experimental research activity focuses on a specific, measurable objective and adheres to the scientific process. This activity involves several steps and requires a time commitment. It relates to a significant scientific or agricultural principle, issue, or question. An instructor supervises the students as they progress in this activity. Some examples of an experimental research program are listed below:

- Comparing the effect of different amounts of light on plant growth
- Comparing two types of fertilizer on plant development
- Analyzing the effectiveness of different display techniques on amount of plant sales in a nursery
- Demonstrating the effect of various levels of soil acidity on plant growth

An analytical activity does not use experimental methods. Rather, the focus is on collecting information from different sources and then evaluating the data. The goal is to create a finished product. Some examples of analytical activities include identifying suitable plants for a perennial garden for a senior center and creating a landscaping ad campaign directed toward new home owners.

Greenhouse Operation and Management

Students can earn awards and participate in interesting activities that relate to the greenhouse industry. Career Development Events sponsor contests in floriculture, nursery/landscape, and agricultural sales. Proficiency awards are granted in horticulture, turf and landscape management, floriculture, fruit and/or vegetable production, and specialty crops.

A final opportunity the greenhouse industry offers agricultural education is in school and community service. Building Our American Communities grants and partnerships with groups like chambers of commerce and garden clubs offer the chance to accomplish something valuable for others. Individuals may provide landscaping on school grounds or make plant arrangements for special school occasions, such as banquets and graduation. Other projects that would benefit the school or community are listed below:

- Create a hummingbird habitat
- Plant a garden with all-native Missouri plants
- Create a garden to attract songbirds and butterflies
- Create a garden that is made up of shade-loving plants
- Grow native plants for a highway project on behalf of the State of Missouri
- Grow plants as a wholesale product to retail operation

Summary

Career opportunities abound in the greenhouse industry. Positions are available in various sectors: at wholesale and retail levels and as a grower, greenhouse technician, production specialist, or marketing manager. Understanding the organizational structure of a greenhouse operation may influence one's career selection. By working hard and refining work skills, it is possible to advance to any level, including manager/owner. The greenhouse industry offers many opportunities for agricultural education.

SAE programs offer valuable hands-on experience.

Credits

Boodley, James W. *The Commercial Greenhouse*, 2nd ed. Albany, NY: Delmar Publishers, 1996.

Garton, Bryan L. and Scott Stone. Agricultural Education, University of Missouri-Columbia. Joint State Staff in Agricultural Education *Agricultural Education Program Planning Handbook for Missouri Schools*. pp. 109-111, 1997.

Greenhouse Operation and Management (Student Reference). University of Missouri-Columbia: Instructional Materials Laboratory, 1990.

"Greenhouse Positions." New Haven Gardens. <<http://www.nhg.com/empgh.htm>> accessed 2/27/02.

"Greenhouse Production and Management." <<http://www-afa.adm.ohio-state.edu/u-majprs/GREENHSE.HTML>> accessed 2/27/02.
"Key #2 - SAE" <www.ffa.org/programs/lps/html/sae.html> accessed 5/6/02.

"Landscaping, Groundskeeping, Nursery, Greenhouse, and Lawn Service Occupations." Yahoo! Careers. <<http://careers.yahoo.com/employment/oco/ocos172.html>> accessed 2/27/02.

"Nursery and Greenhouse Operators and Managers." Career Path. <http://careerpath.tv.org/jobmatters/display.phtml?banner_id=theme&job_id=54> accessed 2/27/02.

"Nursery and Greenhouse Workers." Career Path. <http://careerpath.tv.org/jobmatters/display.phtml?job_id=59&theme=1> accessed 2/27/02.

“Nursery and Greenhouse Workers.”
<<http://www.edinetconnect.com/cat/careers/nurserysw.html>> accessed 2/18/02.

“Welcome to SAE Central.” North Carolina State University. <<http://www.cals.ncsu.edu/agexed/aee322/index.html>> accessed 3/14/02.

UNIT II: THE GROWING STRUCTURE

Lesson 1: Greenhouse Parts, Structures, and Coverings

This lesson addresses site selection, types of greenhouse structures, basic construction of a growing structure, and interior components of a greenhouse. Additional information concerns other structures and areas that are part of most commercial greenhouse operations as well as the exterior layout of buildings and work areas.

Site Selection

One of a greenhouse owner's primary considerations is selecting a suitable site for the growing structure. The greenhouse, even as an indoor structure, is still affected by outdoor elements, such as the direction and intensity of wind, sun, snow, and frost. A region's climate that typically has winter blizzards, spring tornadoes, or summer and fall hurricanes may adversely impact the success of a greenhouse operation.

By studying historical weather patterns, the owner can assess the amount of precipitation, sunlight, and temperature variability in the proposed site.

An optimal location has high, natural light levels and moderate temperatures. Some sites, however, could increase energy and maintenance costs, making them not suitable for a greenhouse. A growing structure in a cold location requires additional heating to sustain plant growth. Sites with extremely high temperatures and humidity increase the costs of ventilation and fans. If a structure is located in high elevations, it is subject to windchill and must compensate by increasing heat. A greenhouse located in a valley protected from harsh winds may be exposed to frost, which also necessitates additional heating.

The topography of the site affects where a growing structure is built. (Topography refers to the shape of the land, e.g., hilly, steep, rocky, flat.) The surface of the ground should be level. A

0-5% slope is recommended. Placing a growing structure on a flat surface is efficient because it facilitates easy adjustments to various mechanical controls in the greenhouse, which is economical. A level surface provides good drainage and reduces the cost of grading the land. Selecting where to place the greenhouse depends on location. The optimal site is where the greenhouse receives the most morning sunlight, thereby promoting the plant food production process (photosynthesis). For example, in Maryland, the optimal direction for a growing structure is toward the south or southeast. The next best option is placing the structure to the southwest, which provides sunlight later in the day. In Missouri, the ridge of the greenhouse should run north and south to permit the light to enter from a sidewall, not an endwall. Winter light is maximized and shadows are reduced. For states whose latitude is 40° north or above, an east-west direction is best.

It is also important to shelter the structure from winter wind. A windbreak, composed of trees, shrubs, or annual or perennial crops, provides a protective barrier that lessens and redirects the force of winter wind. It is usually placed to the north of the greenhouse. To prevent shading the greenhouse, the distance between the windbreak and greenhouse should be two and a half times the maximum tree height. All major obstacles - trees and large buildings - must clear the growing structure.

Another critical factor in site selection is the availability of resources. The site must have an ample supply of water either from the city or a well. During peak use, the greenhouse requires approximately 2 quarts per day per square foot. To ensure water quality, a laboratory or county Extension agent can test for correct pH, alkalinity, and level of soluble salts. Electricity, natural gas,

Greenhouse Operation and Management

and sewer services have to be hooked up, which may involve connection fees. Greenhouses also need convenient access to materials for growing plants (growing media, fertilizers, pesticides, etc.). The greenhouse owner must determine if labor is available to perform both routine and harvest-time duties. Basic services such as waste removal are required. To maintain a competitive edge, the greenhouse owner needs access to sources of information, such as local university Extensions or a nearby testing/advising service.

Land is a major factor in site selection. A greenhouse owner's fundamental concern usually is the cost of the property (purchase price and taxes). Another consideration is selecting land that is close to the main roads so that delivery trucks and customers can easily drive to the greenhouse. For example, a parking area may be necessary. The land should also be near utilities. The ideal site has potential for expansion.

Land selection directly impacts marketing. A retail operation that is visible from the road encourages customers to stop by whenever they wish. For wholesale operations, proximity to markets and suppliers is important. In order to succeed competitively, the greenhouse owner must have easy access to suppliers, raw goods, and customers.

Finally, site selection involves various legal considerations. Permits, licenses, and zoning regulations govern where a greenhouse may be built and often even dictate what type of building materials may be used. Retail greenhouses should be zoned for business. Selecting an appropriate site also involves how the greenhouse operation affects its neighbors. If the proposed site is near a school, hospital, or residential community, the greenhouse must cooperate with the zoning rules of these entities. If water from the site drains into parks, farms, or ecological areas, the land may be subject to various state and federal regulations. Some states require the owner to obtain certification to purchase restricted-use pesticides.

(See Unit VI, Lesson 3, for details.) In addition, the greenhouse owner must also be aware of relevant mandates from the Occupational Safety and Health Administration that ensure employee safety.

Types of Greenhouse Structures

The two basic types of greenhouse structures are freestanding (detached) and connected (attached). Freestanding structures can be constructed in several frame styles. The *even span (gabled)* frame is commonly used. The angle and width of its roof are equal. This frame type can be lengthened. It has more usable space than other types and promotes good air circulation and maintains even temperatures in the greenhouse. The *uneven span* frame, with one roof side longer than the other, is used if the land's slope is not too steep. This structure is placed on hillsides with southern exposure. It captures more of the low light during winter than the even span greenhouses.

The high *gothic arch* frame provides ample headroom and is used primarily to grow potted crops and spring flowering annuals. The *Quonset* frame, developed during World War II, is extremely simple to build and efficiently designed, but its circular frame lowers the sidewall height, which limits headroom and storage space. The design of the *A-frame* provides more space along the sidewalls, which promotes good air circulation. Figure 2.1 illustrates each of these frame types.

Figure 2.1 - Frame Types

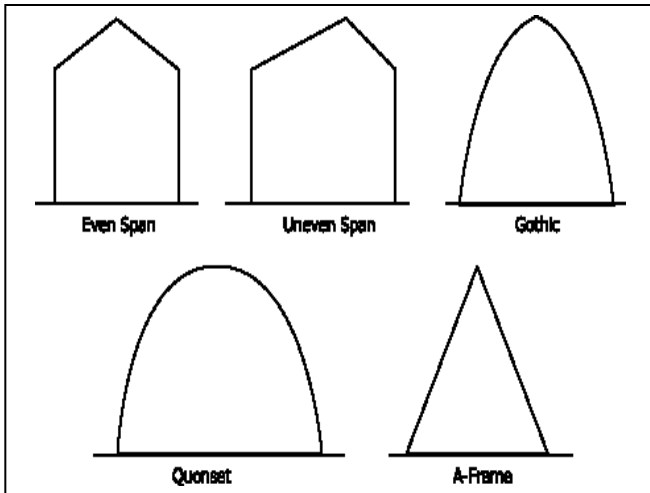

Freestanding structures are easy to maintain. Because there is space between these buildings, shoveling snow from the rooftops can be done with minimal difficulty. Regulating the temperature and ventilating the air are also easier to perform. As a result, plants are not exposed to erratic temperature fluctuations or harsh blasts of cold air. Another advantage of freestanding structures is uniform light with minimal shadows. However, this type of structure costs more to construct because it requires additional sidewalls and occupies more space than a single connected structure. It is also less energy efficient because more surfaces are exposed to the outdoor elements.

The framing styles of connected structures are similar to those listed above, but they are joined by a common roof, typically a *ridge and furrow* construction. The furrows form gutters. (See Figure 2.2.) The interior walls create separate zones for crops.

Figure 2.2 - Ridge and Furrow Construction

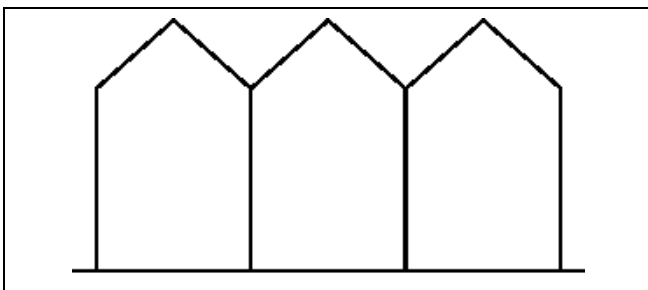

Connected structures occupy less land and have no sidewalls; therefore, fewer materials are needed for construction. Because there are no walls where the gutters are, more interior space is available than in several freestanding structures. Less energy is required to heat and cool the greenhouse because the exposed wall surface area is reduced.

But being connected to another building makes it harder to apply insecticides that produce vapors, gas, smoke, or fumes and to zone heat to specific plants. Another drawback is that the gutters collect snow, making removal very difficult. To avoid excessive accumulation that can collapse the greenhouse, the owner may have to add expensive heat lines to induce melting. Gutters also create shadows, thereby diminishing light intensity. As a result, plants may ripen later than expected. This delay in harvest time can affect the grower's market opportunities.

The *lean-to* is a common example of the connected structure. It is attached to an existing building that generally faces east or south. Confined to a width of about 7-12 feet, this is the least expensive growing structure. Heat, water, and electricity come from the adjacent building. It is often used for forcing bulbs and starting seeds. However, lean-to greenhouses have limited space and less roof support. Figure 2.3 illustrates a lean-to greenhouse.

Figure 2.3 - Lean-To Greenhouse

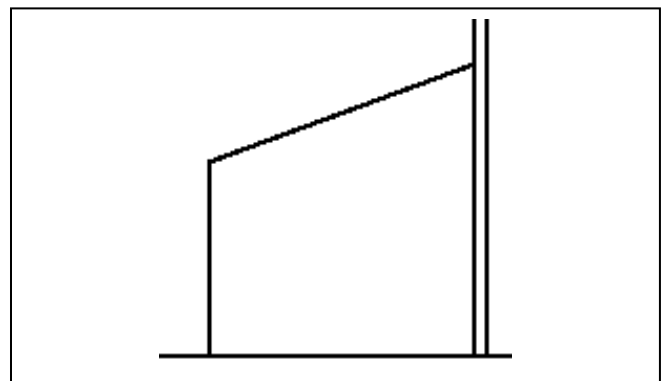

Greenhouse Operation and Management

Several innovations in energy-efficient growing structures have been developed in Europe. The Netherlands developed an energy-efficient growing structure called the “Venlo greenhouse.” The galvanized steel superstructure supports a gable roof. It has a self-supporting glazing bar system. The bars are placed opposite each other, so less material is needed and more light is available. The structure is rust free, requires no maintenance, and lasts for years. The polycarbonate sides and endwalls provide thermal insulation and regulate the temperature inside the greenhouse. High-light glass glazing transmits light very well and promotes high-quality growing environments for the plants. The roof vents are controlled thermostatically or by computer. They cut energy costs by using natural ventilation to cool the greenhouse.

Also from the Netherlands is the “Rovero” greenhouse. It has a retractable roof that can be closed, half closed, or opened as needed. The roof covering is made of clear or diffused polyethylene. The sidewalls and endwalls are motorized and have 8-mm-polycarbonate roll-up curtains. The entire Rovero greenhouse environment is fully computer controlled.

Originally developed in France (as single span) and Spain (as multispans) are field-scale tunnels and conventional tunnel designs.

From “National Polytunnels” in Lancashire, England, cantilevered roof vent units are used. The vents are positioned on top of each roof span; the winch mechanisms can open five vents in a row.

Another innovation is a folding roof that can fold back into the gutter. One model, “Max Air,” comes from National Polytunnels. An additional model is from Polybuild (Surrey, England) in cooperation with the Dutch company HCT.

Construction of a Growing Structure

The basic components of a greenhouse are illustrated in Figure 2.4.

Figure 2.4 - Parts of a Greenhouse

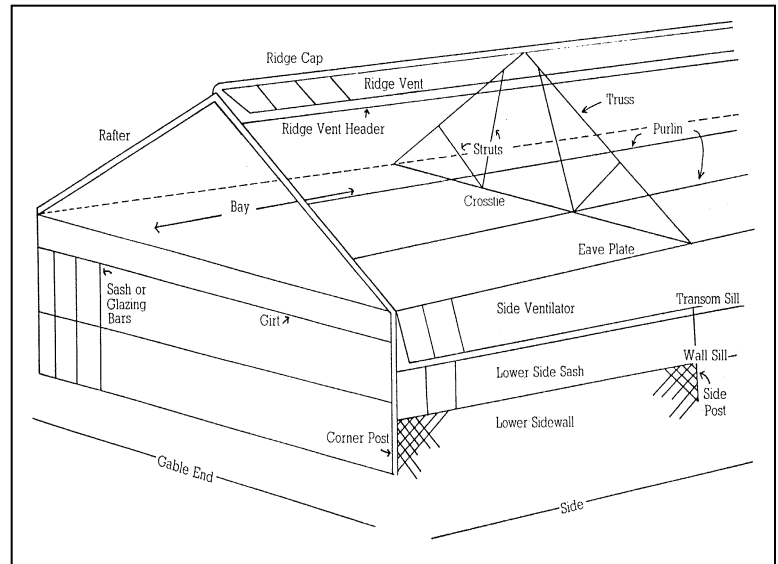

The owner has several decisions to make concerning how to frame the greenhouse: cost of construction and maintenance, strength of the structure, choice of covering materials, and amount of light blocked.

The framing materials may be used alone or in combination. If *wood* is used, it must resist decay. Some trees (e.g., ash, birch, cottonwood, hickory, and pine) are naturally resistant to decay even when untreated and have an average expected life of 15 years. Other trees such as redwood must be treated with either an oil-based or a waterborne, salt-type preservative that is safe for plants. The wood must NOT be treated with chemicals that emit toxic fumes to plants (e.g., creosote and pentachlorophenol, known as PENTA). Painting preservative-treated wood with light-reflecting, white, water-based paint provides further protection.

A better choice of framing material is *aluminum* alloy because it is flexible, durable, affordable, and long lasting. It is a versatile metal, able to conform to various shapes and thicknesses, and can be molded into the desired framing structures.

Steel or iron can also be used for the support structures. Wood and iron create a solid framework that provides strength and stability.

Selecting covering materials entails several factors: style of greenhouse; durability in withstanding snow, wind, and extreme temperatures; cost of construction and maintenance; type of framing that can support the cover; and availability of materials. Other considerations are how the covering affects the interior environment in terms of heat retention, light penetration, light diffusion, condensation potential, and static electricity charge.

Heavy, tempered *glass* is traditionally used because it is strong, inexpensive to maintain, offers excellent light transmission, and is long lasting. But it requires a heavier, more costly framing structure and is also breakable.

Polyethylene film is another type of covering. It is lightweight, flexible, easy to install, and can be supported by a lightweight frame. This film transmits light as well as glass and has the added advantage of using a lighter frame for support. However, plastic film is susceptible to weather damage, accumulates dust so repeated rinsing is needed, and requires frequent replacement.

Other options for covering greenhouses are *rigid plastic panels*, typically made from polycarbonate, fiber-reinforced polyester (FRP; fiberglass), and polymethyl methacrylate acrylic (PMMA). To prevent ultraviolet light from deteriorating the rigid covering, a stabilizer is required. Unfortunately, the stabilizer compromises the strength of polycarbonate. PMMA is tough, light, and durable in the weather. However, it turns yellow and loses its strength under extended exposure to the outdoors. Of all the plastic coverings, FRP lasts the shortest amount of time and requires frequent replacement. FRP transmits approximately 80-90% of the light that glass does.

In general, rigid plastic covers are lightweight, sturdier than film, and durable. However, they can be damaged by the elements over time, which means they must be replaced every 10-20 years.

Interior Parts of a Greenhouse

The interior layout depends on two major factors: how the greenhouse is used (for wholesale or retail purposes) and what type of crop is grown. For a wholesale operation, the arrangement of equipment and buildings should facilitate the work flow so materials and labor can move smoothly through the production process. Maximizing all available space increases production and profit. By arranging plants close together, narrowing the width of the aisles, and placing the benches close together, the owner can use all available space. Hanging plants from the ceiling saves space and promotes a 1/3 increase in sales.

A retail operation also requires an efficient flow of materials but additionally focuses on whether customers can move easily throughout the greenhouse and have access to the merchandise. Important features include placing special displays and the cash register in a convenient location and creating an aesthetic shopping environment. Wide aisles and generously spaced plants invite browsing and promote sales.

The three common layout designs for benching are lengthwise, crosswise, and peninsular as seen in Figure 2.5.

Greenhouse Operation and Management

Figure 2.5 - Interior Layout of a Greenhouse

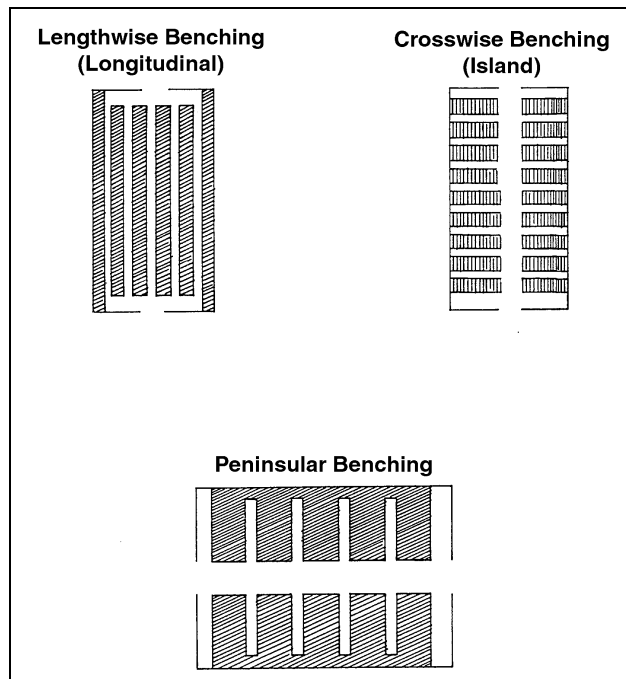

Lengthwise benching is used for cut flowers grown in ground beds and potted plants. The long benches force workers to walk all the way to the end to get to the other side. This reduces efficiency. However, this type of benching supports water and heating lines without hindering walkways.

Crosswise benching uses space more efficiently because the center aisle allows access to each individual bench. This layout is useful for bedding plants and container-grown plants.

Peninsular benching is used for various container-grown plants, starter plants, flowering annuals, and other plants designed for home garden beds. This layout is best suited for retail operations because it provides easy access to plants and more area for growing plants.

The flooring must accommodate equipment and work flow and provide proper drainage. Bare ground is not acceptable because of the risk of pathogens and difficulty in providing drainage. Flooring can be constructed from concrete,

including drain basins and slope toward drains, or it can be made from gravel. A weed mat covered with gravel is porous enough to allow the water to drain.

Benches must be sturdy enough to support the amount of plants. Raised benches should provide air movement between the plants, allow water drainage, and separate the plants to prevent spreading diseases and insects. The three types of benches are fixed, movable, and rolling. The movable benches can be put outdoors in favorable weather and used for double-crop production. (One crop is placed on the floor and second bench is moved outdoors.) Rolling benches maximize use of floor space, use less aisle space, and are intended for wholesale use only.

Benches are made from wood, concrete, metal, or plastic. Wood promotes good air circulation but decays eventually. Concrete is very durable but is hard to move and usually expensive. Metal does not require maintenance but is expensive and has rough edges that must be smoothed. Plastic is very light and easy to clean but is expensive and may not be available in the desired size.

Other Structures and Areas in Commercial Greenhouse Operations

In addition to the greenhouse itself, the greenhouse owner can use three other types of outdoor growing structures: coldframes, hotbeds, and lath houses, as illustrated in Figure 2.6.

Figure 2.6 - Other Outdoor Growing Structures

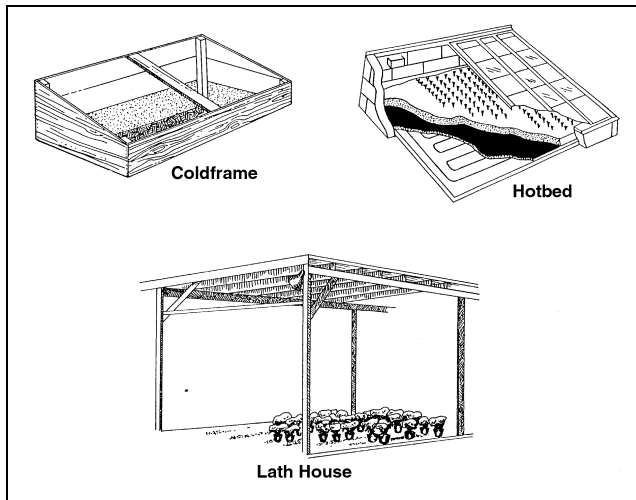

The coldframe is covered with transparent glazing material. The sun is its only source of heat. The top is opened during the day and closed at night. Coldframes are used to harden and protect plants from frost and to store bulbs during winter.

The hotbed also has a transparent covering, but its heat source is steam, hot water, or electricity. Hotbeds are used to start seedlings and cuttings.

The lath house is covered with wooden slats (laths) or shade fabric and supported by vertical poles. The pieces of laths are spaced about 1 inch apart to reduce light intensity and provide shelter from the wind. The sun is the sole source of energy. This structure is used during the summer where the temperature is warm or year-round in warm climates to propagate tropical plants and plants needing shade.

Additional areas used in most commercial greenhouse operations include workspaces for soil mixing and propagation, storage areas, roadways, and loading and shipping areas. Retail operations typically have parking lots, display areas, rest rooms, offices, break room, and kitchen area.

Summary

Building a growing structure for a greenhouse operation presents the owner with several important decisions. Site selection involves climate, topography, available resources, land, marketing decisions, and legal issues. There are several different types of growing structures to choose from, depending upon the scope of the operation.

Credits

“The Best in Dutch Venlo Technology.”
<<http://www.roughbros.com/html/venlo.html>>
accessed 5/7/02.

Boodley, James W. *The Commercial Greenhouse*, 2nd ed. Albany, NY: Delmar Publishers, 1996.

Duncan, G.A. and J.N. Walker. “Preservative Treatment of Greenhouse Wood.” <<http://www.ca.uky.edu/agc/pubs/aen/aen6/aen6.htm>>
accessed 1/14/02.

“Greenhouse Management - Site Analysis.”
<<http://www.sfasu.edu/ag/horticulture/hrt321/3.%20HRT%/20Site%20Analysis%20.htm>>
accessed 1/4/02.

“Greenhouse/Nursery Layout and Site Selection.”
<<http://envhort.ucdavis.edu/ehweb/enh125/general/SiteSelect.htm>> accessed 12/18/01.

Greenhouse Operation and Management (Student Reference). University of Missouri-Columbia: Instructional Materials Laboratory, 1990.

“Greenhouse Structures.”
<<http://aggie-horticulture.tamu.edu/greenhouse/guides/green/struc.html>> accessed 12/17/01.

Greenhouse Operation and Management

Hall, Karen. "Greenhouse Site Selection & Regulation." Cornell Cooperative Extension. <http://aem.Cornell.edu/special_programs/hortmgmt/pres/2000_Greenhouse_Conference/Hall.ppt> accessed 1/15/02.

Herren, Ray V. and Roy L. Donahue. *The Agriculture Dictionary*. Albany, NY: Delmar Publishers Inc., 1991.

Kessler, J.R., Jr. "Hobby Greenhouse Operations and Practices." Auburn University. <<http://www.aces.edu/department.extcomm/publications/anr/anr-1153/anr-1153.html>> accessed 12/19/01.

"Products" <<http://www.bosch-inveka.nl/english/content-producten.htm>> accessed 5/7/02.

"Retractable Roof Greenhouses." Rovero. <<http://igcusa.com/rovero.htm>> accessed 5/7/02.

Ross, David S. "Planning and Building a Greenhouse." Center for Agricultural & Natural Resources Development, West Virginia University. Adapted from Fact Sheet 645 - University of Maryland, Extension Service, Department of Agricultural Engineering. <<http://www.wvu.edu/~agexten/hortcult/greenhou/building.htm>> accessed 1/14/02.

"Where in Your Market Will You Locate Your Business?" <<http://www.aces.edu/department/extcomm/publications/anr/anr-691/anr-691.html>> accessed 12/19/01.

UNIT II: THE GROWING STRUCTURE

Lesson 2: Environmental Control

Various environmental factors influence greenhouse operations. This lesson addresses types of environmental controls found in the greenhouse. It examines how temperature is monitored and controlled; how to keep a greenhouse warm, ventilated, and cool during appropriate times; and how to control the humidity. Equipment used in irrigation is also discussed as well as the effect of carbon dioxide and light levels.

Types of Environmental Controls

Several natural elements must be controlled in a greenhouse: temperature, humidity, water, light, carbon dioxide, pests, and diseases. These factors can be manipulated through one of three basic methods: manual, automated, or an integrated control system. If a greenhouse owner manually controls a thermostat, he or she has to physically move the setting. If that thermostat is automatically controlled, the setting is triggered mechanically; the greenhouse owner would not touch it at all.

The integrated control system provides analog and computer systems and multiple sensors throughout the greenhouse. It senses and controls air and soil temperature, light intensity, relative humidity, and carbon dioxide levels. It also records data for evaluating and troubleshooting and provides data for planning future crops.

Monitoring and Controlling Temperature

Before selecting a temperature control system, a greenhouse owner has to consider the cost of equipment, which includes installation and maintenance. To enhance plant growth, the system must also provide uniform control

throughout the greenhouse by minimizing hot and cold spots and providing horizontal airflow.

The temperature control system regulates temperature extremes to suit the needs of the entire operation. To be reliable, this system should have a backup emergency generator and an alarm that signals when a power failure occurs so that the owner will know when any outages threaten the operation.

Selecting the type of fuel to run the temperature control system depends on cost, availability, storage requirements, and means of transporting the fuel to the greenhouse.

Several kinds of devices are used to monitor and control air temperature: thermometer, high/low thermometer that measures during the day and night, or thermostats that provide on-off control and step control (stages). Aspirated thermostats (drawing air by suction) read the temperature of air blown across the thermostat and are a more accurate control than standard thermostats. Thermistors are electronic semiconductors that sense even subtle temperature changes and signal the controller. Figure 2.7 illustrates these monitoring devices.

Greenhouse Operation and Management

Figure 2.7 - Devices to Monitor Temperature

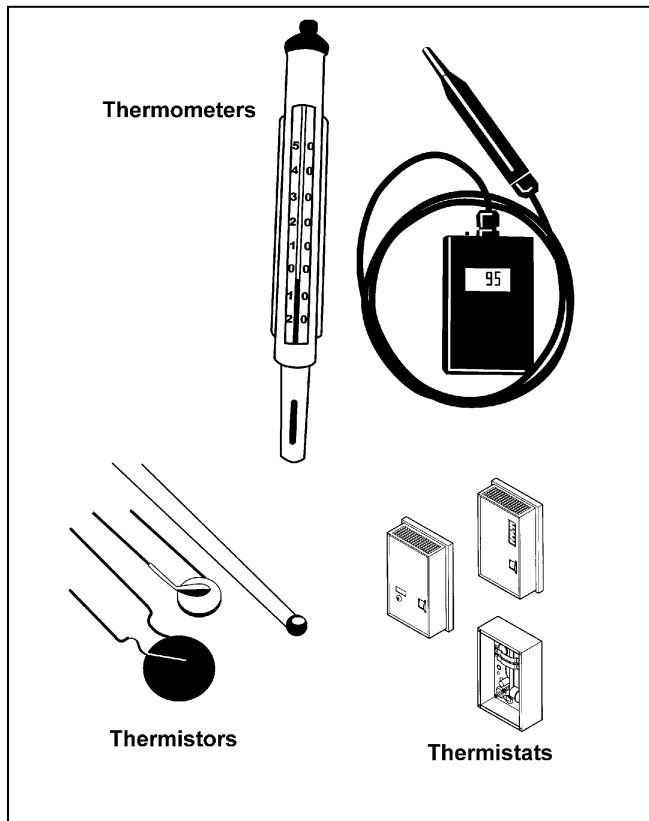

The monitoring devices should be level with the plants throughout the greenhouse, shaded from direct sunlight, and away from cooling fans.

Keeping a Greenhouse Warm During Cold Weather

Heat loss occurs in three ways. Through conduction, energy is lost through the materials that cover the greenhouse. Air infiltration permits heat to escape through leaks in the greenhouse's coverings, doors, and windows. Radiation occurs when warm objects emit energy that passes through the air to colder objects but does not warm the surrounding air to any degree. To protect plants in the greenhouse, all lost heat must be replenished. Heat should be energy efficient, reliable, and safe.

Heat is measured in Btu - British thermal units; 1 Btu raises 1 lb of water 1°F. A typical boiler needs

33,475 Btu. This guideline may affect the owner's selection of fuel in terms of cost and availability.

Solar energy provides only some heat. The greenhouse collects and stores the energy from the sun that passes through the covering during the day. This heat warms the plants and other objects inside the greenhouse. The heat that is radiated back does not have enough energy to pass back through the covering (causing the "greenhouse effect"). Heat is retained at night (the amount retained varies with the type of covering). Solar heat alone is not sufficient for greenhouses in most northern climates. An additional source of heat must be provided.

Heating equipment includes unit heaters, central heaters, and radiant (infrared) heat. Infrared light warms surfaces (plants, soil, benches, etc.), not the air. Air is warmed only by heat radiated from surfaces. Emergency generators also provide heat. Generators, fueled by gas or fuel, provide supplemental power if an outage cuts off the electric fans that are essential to most heating and cooling systems.

There are three basic types of heat distribution. In forced hot air, the heat comes from burning several types of fuel, such as natural gas. The heat is distributed throughout the greenhouse and ventilated outside to prevent buildup of air pollutants. Mounted on the ground or overhead are horizontal discharge unit heaters that push the air through perforated polyethylene tubing that hangs above plants. In addition, vertical discharge unit heaters fans are mounted overhead and they move the air downward. The unit heaters use horizontal airflow (HAF) fans that help distribute the heat evenly.

Hot water is piped through the greenhouse by metal piping that is placed along walls and under benches. The temperature is variable. A circulating pump moves the water.

Greenhouse Operation and Management

Steam heat distributes steam through the greenhouse by metal pipes, but the temperature is not as variable as with hot water. Steam heat carries more heat and moves farther than hot water heating.

Coal, kerosene oil, propane/natural gas, wood, and electricity are examples of fuel sources that can heat a greenhouse. Price and availability are determining factors. Electricity is generally not an efficient fuel for most commercial greenhouse operations.

Ventilating a Greenhouse

Venting is important. Any heating system that burns fuel can be lethal to humans. When oxygen is deleted from the air, this shortage creates carbon monoxide - a gas that is fatal to humans. Impurities in fuel (e.g., ethylene gas and sulfur dioxide gas) and incomplete combustion can create other toxic fumes. To ensure safety, fuel-burning heat sources must be vented to the outdoors through a chimney. A ventilation system must be installed to bring fresh air into the greenhouse. Air circulation is essential to the heating process. Air-mixing fans push the rising hot air back down to the plants.

The purpose of greenhouse ventilation is to bring fresh air into the greenhouse and reduce temperature and relative humidity. Excessive humidity causes condensation. If condensation is left on plants, the risk of plant disease increases. Ventilation helps replenish carbon dioxide (CO₂), a necessary ingredient in plant growth that is consumed by plants during photosynthesis.

Types of ventilation include ridge and side vents that have a chimney effect and operate automatically or manually. Exhaust fans on sidewalls and endwalls draw in fresh air and are most beneficial in late spring, summer, and early autumn. Motorized louvers let in fresh air. Fans mix air with inside air then distribute air through a convection tube. The convection tube (running the

length of the greenhouse overhead) distributes air through the perforated openings. See Figure 2.8.

Figure 2.8 - Methods of Ventilation

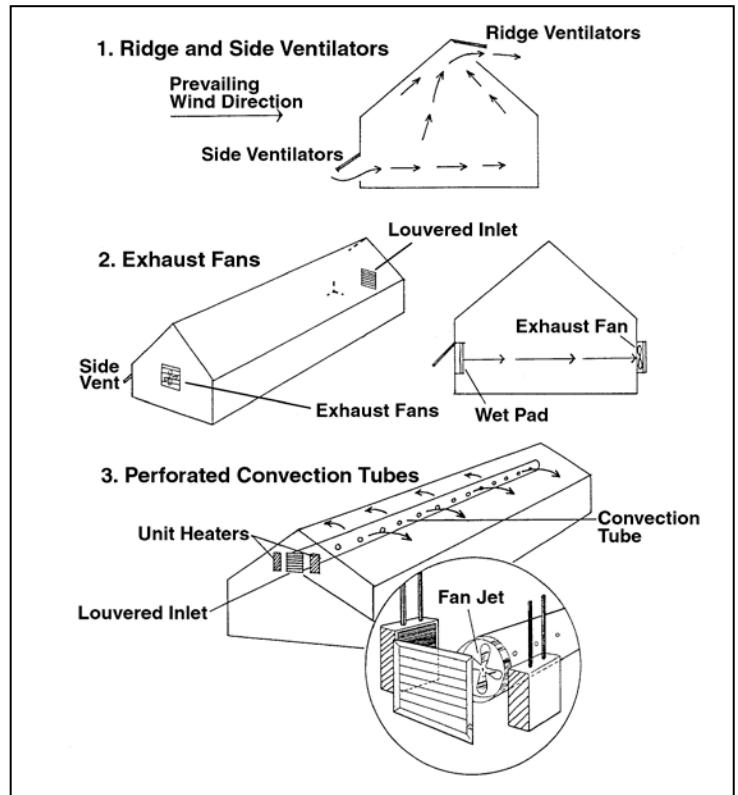

Cooling a Greenhouse During Warm Weather

The simplest way to cool a greenhouse during warm weather is to provide an even flow of cool air and reduce light intensity. The methods of providing cool air include ventilators/ vents, forced air ventilation, and fan and pad systems. In the fog system, water is forced through tiny nozzles to create a fine mist, and the evaporated water cools the air. Mechanical air conditioning systems are not efficient cooling methods for most commercial greenhouse operations.

Shade fabric helps reduce light intensity. The fabric is available in a woven polyethylene cloth and also in a knitted polyaluminum cloth called "Aluminet"; both can be obtained from greenhouse suppliers. The weave densities

Greenhouse Operation and Management

determine how much light is shaded out. The densities range from 20 to 90%. The percentage approximates how much the light intensity is decreased. For example, a 55% shade fabric blocks or excludes approximately 55% of the ambient (surrounding) light. The owner selects the desired density for the operation. The fabric reduces heat best when the cloth is draped on the outside of greenhouse but it should be arranged so it does not interfere with ventilation.

Shade paint also helps diminish light. It is a diluted, weak-binding latex paint that is sprayed on the outside of the glazing, usually twice yearly. Typically, it wears off gradually during the summer and fall. But it can also be washed off easily with soap and water. The paint should be removed before winter to prevent light reduction during that time of year.

Another method for reducing light is to install wooden, plastic, or plastic-coated blinds and to mount them on the outside of the greenhouse, just like the shade fabric. Alternatively, adjustable blinds can be mounted inside. A final technique for reducing light intensity is to install thermal screens on ceilings and walls.

Controlling Greenhouse Humidity

Relative humidity (RH) measures how much water is dissolved in the air at a specific temperature. It is the ratio of how much moisture is actually in the air at a given temperature compared to the maximum amount possible without condensation. RH is expressed as a percentage. The ideal range of RH for most greenhouse plants is 45-85%. Greenhouse peppers thrive at 75% RH; African orchids prefer 40-60% RH. For roses, the ideal RH is 80%.

If the RH is above 85%, water may condense on plants and increase the risk of fungal pathogens and diseases. (However, cut tulips and cut daffodils should be stored at over 90% RH.) If the RH is below 45%, stunted plant growth or leaf

burn may occur. More watering is required. (Yet succulents and cacti do best in 5-15% RH.) To maintain proper RH, the greenhouse owner can use shading to reduce temperature and light as well as cooling pads (evaporative cooling). By keeping the greenhouse filled with plants, humidity is maintained because plants generate RH. Do not water plants late in the day and ensure that the greenhouse floor drains well.

To maintain the proper humidity level, install a fan in the greenhouse and set its timer to start operating at 9:00 p.m. or 10:00 p.m. for 30-60 minutes. This exchanges moist, warm, inside air with moist, cool, outside air. This enables the heating system to warm the air to its set point, which reduces the level of water in the greenhouse.

Open the roof ventilators to let the hot air escape. (Maximize the exchange of air by having wide roof ventilators and a double row of sidewall ventilators.) This prevents moisture from increasing and also prevents water vapor from condensing on plants, which can cause the spread of diseases.

Installing fans for ventilation during late spring, summer, or early fall introduces cooler outside air into the greenhouse. This helps sustain the proper humidity level. During late autumn, winter, and early spring, introduce air into the greenhouse through perforated polyethylene tubes. This prevents harsh, extremely cold outside air from harming plants. When cold air leaves the tubes, it mixes with warm greenhouse air, thereby preventing plants from suddenly getting chilled. Exhaust fans exchange greenhouse air with outside air.

Irrigation Equipment

Irrigation methods use either manual or automatic equipment. Manual irrigation systems use handheld hoses and wands. Automated irrigation systems use the following equipment:

- Mist systems
- Spaghetti tubes controlled by timers
- Drip emitters
- Ooze tubes
- Water loop
- Capillary mat system
- Ebb and flood system
- Boom system
- Spray stake/nozzle system
- Fertigators

See Unit IV, Lesson 3, for a discussion of how equipment and systems are used to irrigate greenhouse crops.

Controlling Carbon Dioxide

Carbon dioxide is essential for plant survival. Plants consume CO₂ during photosynthesis, so the CO₂ levels drop during this process. If the greenhouse is tightly closed, it does not allow any exchange of air. Lost CO₂ must be replenished. Ventilation and light restore some carbon dioxide, but a CO₂ generator is especially effective in enriching the greenhouse.

Carbon dioxide generators provide a maximum amount of CO₂ with a minimum amount of heat as a by-product. The generator has a timer that regulates when to introduce CO₂ into the greenhouse. The recommended time to add CO₂ is at sunrise or when artificial lighting is turned on. The time to discontinue CO₂ enrichment is during dark hours. The amount of CO₂ that should be added into the greenhouse is quantified in units called “parts per million” (ppm). The average recommended level of CO₂ is 1,000-2,000 ppm.

The CO₂ generator operates by burning propane or natural gas. A thermocouple monitors the pilot light. If the pilot flame goes out, a safety valve closes to prevent unburned fuel from releasing into greenhouse. It is best to purchase a large generator rather than a small one. Large generators allow the greenhouse owner to set a shorter cycle time. A shorter cycle time adds CO₂ into the greenhouse more efficiently.

Controlling Light Levels

The amount of light intensity needed in a greenhouse depends on the plant. Intensity of available light is measured in foot-candles (f.c.), which range from 500 f.c. on an overcast winter day to 10,000 f.c. on a clear summer day. (Unit IV, Lesson 1, provides more details on foot-candles.) Environmental factors that affect light intensity are geographic location, season, time of day, pollution, and cloud cover.

Light intensity can be read by a light meter or a computerized photocell. Light intensity can be increased or decreased to meet the plant’s requirements.

Light intensity/day length can be increased with supplemental lights such as fluorescent lights or high-intensity discharge lights. Using black material to block plants from light decreases light intensity/day length. Putting plants under a bench reduces exposure to light. Spraying a shading compound on the growing structure and placing a shade cloth above plants or over the growing structure also decrease light intensity.

Summary

Temperature, heat, ventilation, relative humidity, irrigation, levels of carbon dioxide, and light intensity must be regulated within the greenhouse. Careful monitoring of these environmental controls helps promote crop yield and profit for the greenhouse operation.

Greenhouse Operation and Management

Credits

“Aluminet Thermal & Shade Screens.” Greenfire, Inc., 1998. <<http://www.greenhfire.net/hot/G106.html>> accessed 5/13/02.

Ball, Vic, Editor. *Ball Red Book Greenhouse Growing*, 14th ed., Reston, VA: Reston Publishing, Inc., 1985.

Boodley, James W. *The Commercial Greenhouse*, 2nd ed. Albany, NY: Delmar Publishers, 1996.

“Greenhouse Climate Control.” <<http://envhort.ucdavis.edu/ehweb/enh125/GrhEnv/HeatCool.htm>> accessed 12/18/01.

“Greenhouse Management - Cooling.” <<http://www.sfasu.edu/ag/horticulture/hrt321/6.%20%20HRT20321%20Cooling.htm>> accessed 1/4/02.

“Greenhouse Management - Heating.” <<http://www.sfasu.edu/ag/horticulture/hrt321/5.%20%20HRT20321%20Heating.htm>> accessed 1/4/02.

Greenhouse Operation and Management (Student Reference). University of Missouri-Columbia: Instructional Materials Laboratory, 1990.

Herren, Ray V. and Roy L. Donahue. *The Agriculture Dictionary*. Albany, NY: Delmar Publishers Inc., 1991.

“Horticulture 321 - CO₂ - Light - Temperature.” <<http://www.sfasu.edu/ag/horticulturehrt...1%20CO2,%20Temperature%20and%20Light.htm>> accessed 5/8/02.

Kessler, J.R., Jr. “Hobby Greenhouse Operations and Practices.” Auburn University. <<http://www.aces.edu/department.extcomm/publications/anr/anr-1153/anr-1153.html>> accessed 12/19/01.

“Principles of Carbon Dioxide Enrichment.” <<http://www.litemanu.com/prinsco2.html>> accessed 5/8/02.

UNIT II: THE GROWING STRUCTURE

Lesson 3: Energy Conservation and Environmental Protection

This lesson describes several greenhouse modifications and procedures that the greenhouse owner can implement to conserve energy and protect the environment.

Greenhouse Modifications and Procedures Used to Conserve Energy

Optimizing natural light intensity minimizes the need for supplemental electric lighting. This can be accomplished by preventing large trees, buildings, etc., from shadowing growing structures. Painting interior surfaces (benches, frames, etc.) with white latex paint also brightens the greenhouse and intensifies the available light in the room. Do not use an oil-based paint. To maximize heating and cooling efficiency, it is wise to invest in high-quality heating, cooling, and ventilation systems. An energy-efficient system that uses economic, available fuel saves money and power.

Routine maintenance ensures optimal efficiency. It is important to get rid of debris in all parts of the system, calibrate the thermostat properly, and create energy-saving structures. The greenhouse owner should also check the growing structure for air leaks and ensure that vents and fan louvers seal tightly. Other preventative measures include sealing holes or cracks in the greenhouse covering and installing weather stripping around doors, windows, etc. Protecting the greenhouse from harsh weather is extremely important. During winter, the north-facing side needs insulation. Creating windbreaks helps protect plants from harsh weather. Whenever needed, high-intensity light bursts should be screened out. Also, installing thermal blankets inside the walls and roof helps conserve heat.

Greenhouse Modifications and Procedures Used to Protect the Environment

When constructing and operating a greenhouse, the owner should follow all government regulations. The structure's design or modifications should minimize the use of hazardous pesticides and other chemicals. Use the least toxic method of controlling pests. To ensure an optimal environment for plants, lower the humidity to reduce the risk of disease. Installing a humidity control system helps regulate the amount of moisture in the greenhouse. Providing adequate spacing for plants facilitates growth.

To prevent pests from entering the greenhouse, place screens over vents, construct screened entryways, and isolate and inspect all new material upon arrival

The owner can prevent the development of runoff pollution from water-fertilizer solutions by carefully designing or modifying the greenhouse site and its structures. A suitable location helps protect the integrity of the environment if it offers good drainage and an irrigation system that can be recycled.

Summary

The greenhouse owner should implement techniques that conserve energy and protect the environment. Various modifications, such as optimizing interior lighting and painting the interior with white latex, minimize the need for supplemental electricity. Installing a humidity system regulates the growing environment and enhances plant development.

Greenhouse Operation and Management

Credits

Boodley, James W. *The Commercial Greenhouse*, 2nd ed. Albany, NY: Delmar Publishers, 1996.

Greenhouse Operation and Management (Student Reference). University of Missouri-Columbia: Instructional Materials Laboratory, 1990.

Herren, Ray V. and Roy L. Donahue. *The Agriculture Dictionary*. Albany, NY: Delmar Publishers Inc., 1991.

Kessler, J.R. Jr. "Hobby Greenhouse Operations and Practices." Auburn University. <<http://www.aces.edu/department.extcomm/publications/anr/anr-1153/anr-1153.html>> accessed 12/19/01.

UNIT III: Plant Science Basics

Lesson 1: Plant Parts, Structures, and Functions

As the greenhouse owner develops experience growing various crops, he or she can identify how the needs of each plant differ. This increased awareness may be supplemented further by learning about the structures and functions of plant parts. Lesson 1 provides fundamentals of plant science. It describes the parts of plant cells and types of specialized plant tissues. The functions and types of seeds, roots, stems, leaves, and flowers are identified. Distinctions between monocots, dicots, monoecious, and dioecious plants are also summarized. The background information presented here supports the more detailed description of plants' life processes discussed in the next lesson.

Structure of a Plant Cell

The basic structural unit of plants is the cell, as illustrated in Figure 3.1.

Figure 3.1 - Basic Structure of a Plant Cell

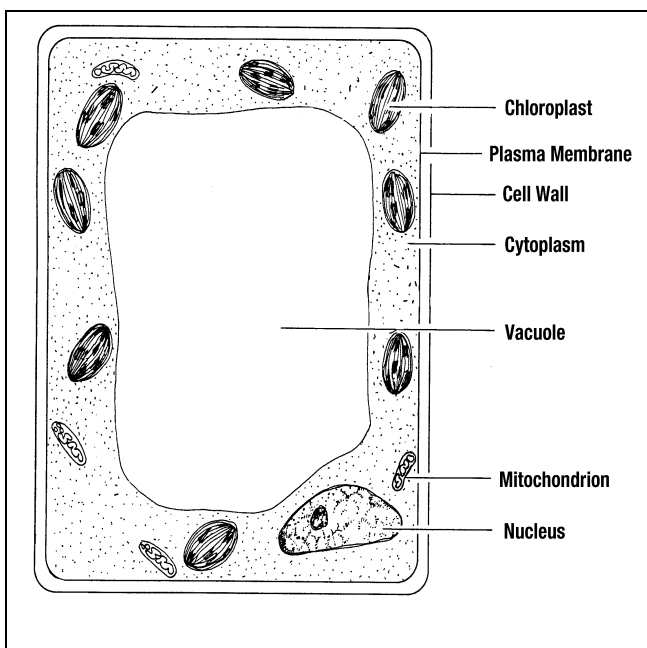

Although the outward shapes of plant cells may vary, the interior structure of cells is generally the same. The cell wall is composed of a primary wall, which develops first and is located where cells grow and divide actively. Within the primary wall, a secondary wall forms. It helps the cell wall become more rigid and eventually develops into the woody part of the plant during the growing process. With the addition of a second cell, the cell walls meet. The layer formed between these new cells is the middle lamella.

The plasma membrane (outer membrane) surrounds the cell and is located just inside the cell wall. It contains proteins, carbohydrates, phosphorous, and fat molecules. The plasma membrane controls the entrance and exit of all substances (e.g., water) from the cell and relays information about environmental conditions to the cell nucleus.

Cytoplasm, also called protoplasm, is the liquid within the plant cell. It is where most of the plant's life processes occur. Cytoplasm is made up of organelles, which are specialized cells bound in a membrane sack. Three important types of organelles are mitochondria, plastids, and vacuoles.

Small and dense, *mitochondria* control many cellular chemical reactions, among the most significant, the production of energy needed for growth. This energy develops during respiration, which is discussed in the next lesson.

Plastids contain chloroplasts and chromoplasts. A chloroplast is the green pigment - chlorophyll - that is essential for photosynthesis, which is explained in Lesson 2. The red, orange, and yellow pigments found in chromoplasts give petals their color.

Greenhouse Operation and Management

Vacuoles are large, fluid-filled areas within the cell that store water, dissolved minerals, and other materials. Individual vacuoles enlarge and join together to form a large, central vacuole when the plant nears maturity. The central vacuole becomes the cell's main storage area.

A crucial organelle is the nucleus, the cell's control center. It contains all of the plant's genetic material (DNA and RNA) within the chromosomes. This determines the plant's physiological characteristics and appearance. The genetic makeup within the chromosomes transmits these inherited traits to succeeding generations.

Differences Between Monocots and Dicots

Plants with one seed leaf (one cotyledon) are monocots. In monocots, the leaves have parallel veins and the vascular bundles are scattered within the stem. Parts of a monocot flower are

displayed in multiples of three. Corn and grass are examples of monocots.

If a plant has two seed leaves (two cotyledons), it is a dicot. In contrast to a monocot, its leaves have branched veins and the vascular bundles are arranged in a circular pattern. Flower parts come in multiples of four and five. The dicot does not have an endosperm. Instead, the two cotyledons that surround the embryo on both sides function as a food storage area for the new plants.

Figure 3.2 illustrates the interior structure of monocot and dicot seeds. The monocot (corn) is on the left side; the dicot (bean) is on the right.

Figure 3.2 - Cross-Sections of Monocot and Dicot Seeds

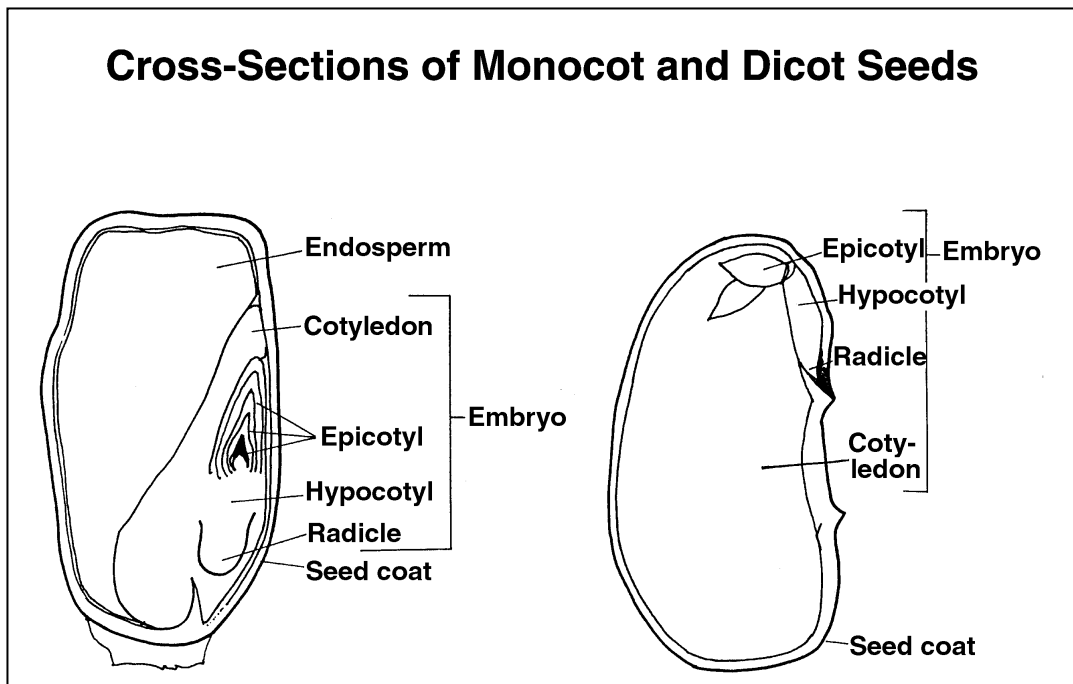

To summarize the distinctions between monocot and dicot plants, see Figure 3.3.

Figure 3.3 - Monocots vs. Dicots

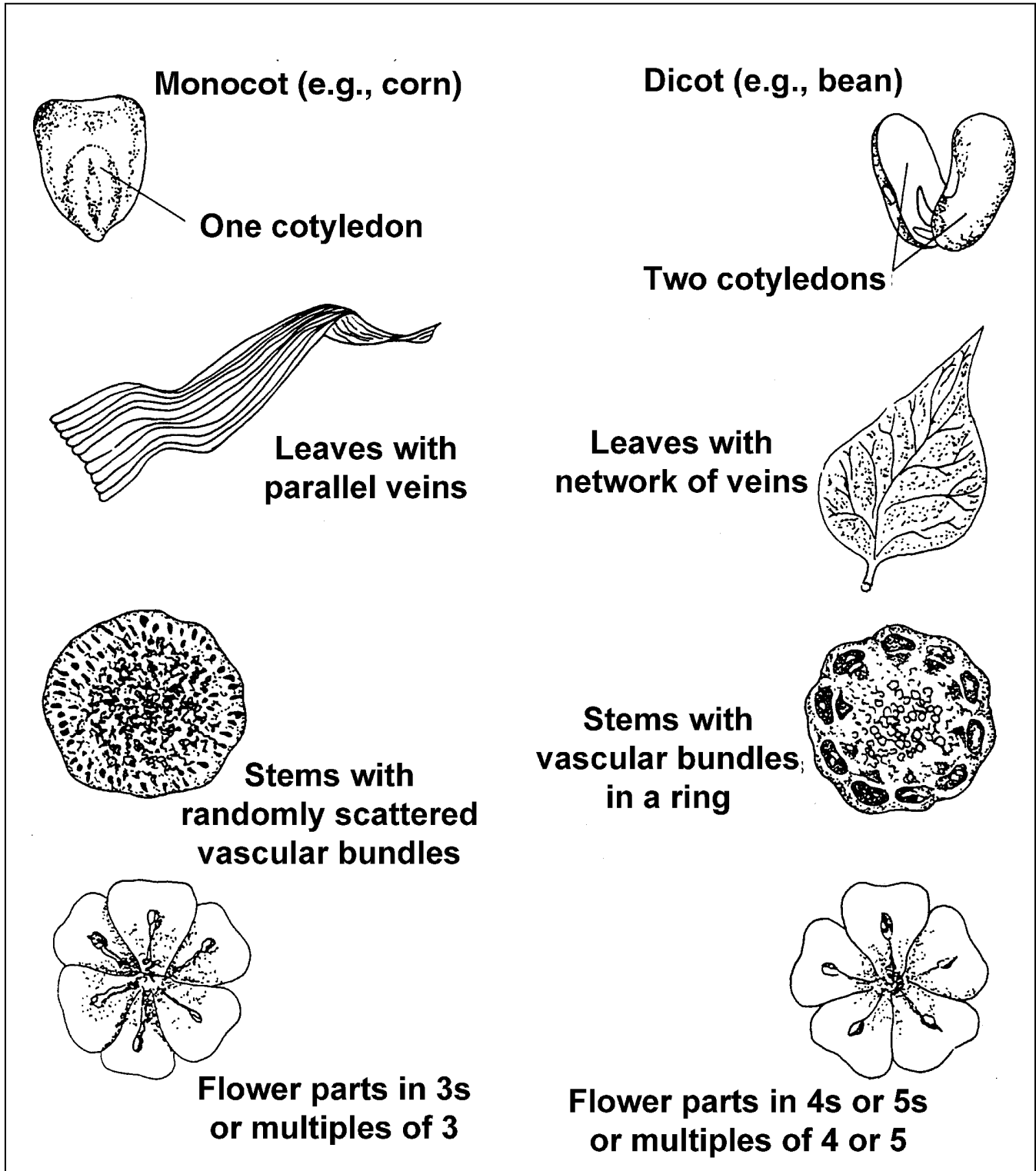

Greenhouse Operation and Management

Specialized Plant Tissues

When cells combine and function together, they form tissues. In plants, the two primary types of tissues are meristem and permanent. In *meristem tissues*, new growth occurs because the cells are rapidly dividing. Three specialized meristem tissues support this process: apical, cambium, and intercalary zone. In apical meristem tissues, growth occurs at the tips of the roots and stems, which lengthens the height of the plant. See Figure 3.4.

Figure 3.4 - Parts of a Plant

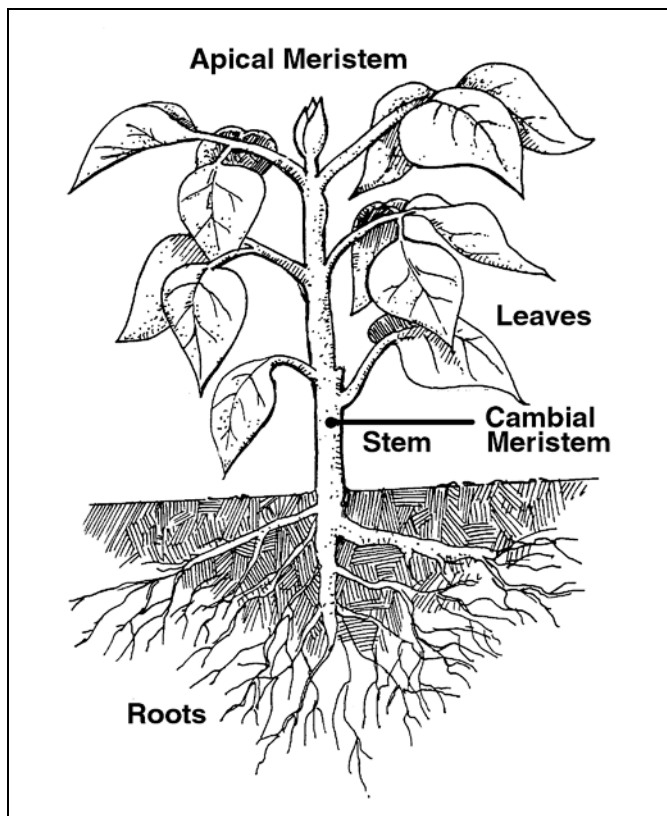

Located in the stems, cambium meristem tissues increase the plant's diameter. The intercalary zone meristem tissues lengthen the plant. These tissues are located just above the nodes (swollen areas at the joints of stems where buds and leaves originate) in plants that have a single seed leaf (cotyledon).

The mature cells in permanent tissues do not actively divide. The specialized permanent tissues are the epidermis and the vascular system. As the outside covering, the *epidermis* supports and protects cells within the plant. Its primary purpose is to regulate the movement of gas and water into and out of the cells.

The *vascular system* creates a path that transmits essential nutrients from the roots through the stem to the leaves. It is made up of two specialized tissues: xylem and phloem. Xylem moves dissolved minerals and water upward through the plant. Phloem moves food, created during photosynthesis, from the leaves to the stem and roots and then provides a storage area for the food. This source of nutrition enhances growth in the meristem tissues, and the food then becomes accessible to all cells immediately.

Parts and Functions of Seeds

The five basic parts of plants are seeds, roots, stem, leaves, and flowers. A seed is a young plant in its earliest stage of development. It has a supply of food that remains dormant until favorable environmental conditions, such as sunlight and rainfall, permit germination. The three basic parts of monocot seeds are the seed coat, embryo, and endosperm.

The tough exterior surface of the *seed coat* protects the embryo from drying out or sustaining injury. The *embryo* is the immature plant within the seed. The embryo is composed of the cotyledon, epicotyl, hypocotyl, and radicle. A cotyledon is the first leaf that develops, called the seed leaf. In monocots, one cotyledon protects the epicotyl. In dicots, two cotyledons protect the epicotyl and provide food storage for new plants. The epicotyl (plumule) is the embryo's growth bud located above the cotyledons. When the seed germinates, it is the first shoot to appear.

The hypocotyl, located below the cotyledon, is the first true stem. As the seed develops, the

hypocotyl gets longer and the cotyledons and epicotyl become visible.

At the end of the hypocotyl is the radicle (root tip), the plant's first root, which is the first part of the plant that emerges from the germinated seed. It anchors the plant in the soil while absorbing essential nutrients and water.

The purpose of an embryo's *endosperm* is to store food for the growing plant and to provide immediate nourishment until the plant can sustain itself through photosynthesis. Endosperms are found only in monocot seedlings.

Functions and Types of Roots

The functions of roots are to hold plants securely to the soil and to absorb water and nutrients that are essential for growth. Specialized functions of roots include synthesizing hormones for plant growth, storing carbohydrates, and providing aerial support for plants such as climbing roots (ivy).

Roots have tiny root hairs – single cell, hairlike extensions whose growth is influenced by moisture. More hairs are produced under dry condition; fewer hairs are produced under moist conditions. Root hairs are found near the tip of the roots and absorb water and minerals from the soil. To ensure greater absorption for the plant, they

expand the root area. The five types of roots are fibrous, taproot, adventitious, aerial, and aquatic, as illustrated in Figure 3.5.

In plants with *fibrous roots*, there is no central anchored root. Instead, delicately branched secondary roots grow; the root system is shallow and wide. Because fibrous roots cover a wide area, they can absorb water and minerals very well and also hold the soil effectively, thereby reducing erosion. Monocots, e.g. grass, typically have fibrous roots.

The *taproot*, or primary or true root, is a large, central root that penetrates deeply into the soil. Other roots radiate from it. It anchors the plant securely in the soil and stores food. Taproots are commonly found in dicots, such as carrots.

Adventitious roots develop in places other than nodes and can form on cuttings and stems. Raspberries and blackberries are good examples of plants with adventitious roots. *Aquatic roots* absorb nutrients and oxygen from water such as in water lilies.

There are two types of *aerial roots*. The clinging air roots grow horizontally from the stem and fasten the plant to a support structure. English ivy has aerial roots. Absorptive air roots, as found in orchids, have a thick outer covering of dead tissue. The roots absorb and store water.

Figure 3.5 - Types of Roots

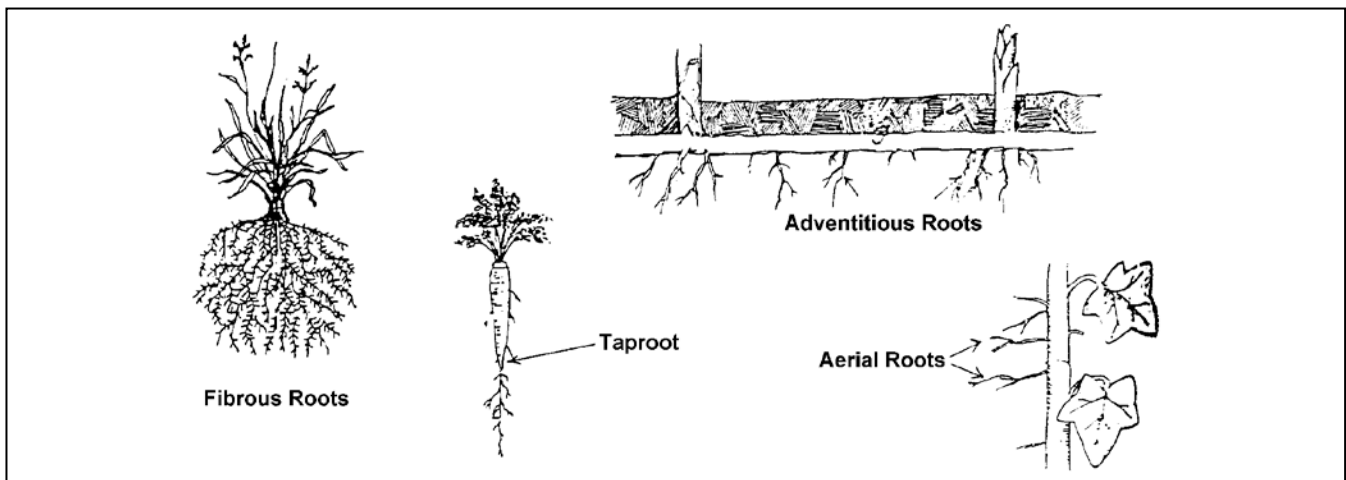

Greenhouse Operation and Management

Functions, Structures, and Types of Stems

The stem supports other parts of the plant, namely, the branches, leaves, flowers, and fruit. By providing height, the stem exposes the plant to the sun so photosynthesis can occur. Some stems are directly responsible for capturing light. The vascular system in stems moves dissolved minerals, water, and photosynthesized food. Modified stems can also store food, minerals, and water in some plants, such as Irish potatoes and cacti.

In vascular plants, the two basic types of stems are monocots and dicots. The distinction between them is based on how the vascular bundles (xylem and phloem tissues) are arranged. In monocots, the vascular bundles are scattered throughout the inner part of the stem called the cortex. In dicots, the vascular bundles are arranged in a ring. Within the center of the stem, there is a region made up of specialized tissues (parenchyma cells) called the pith. Monocots do not have pith. Dicots, on the other hand, have pith in the center of the stem.

Specialized stems grow above or below the ground, not upright or vertically as other stems. These modified stems include corms, tubers, bulbs, crowns, spurs, rhizomes, and stolons. See Figure 3.6.

Corms grow underground and have thickened,

Figure 3.6 - Specialized Stems

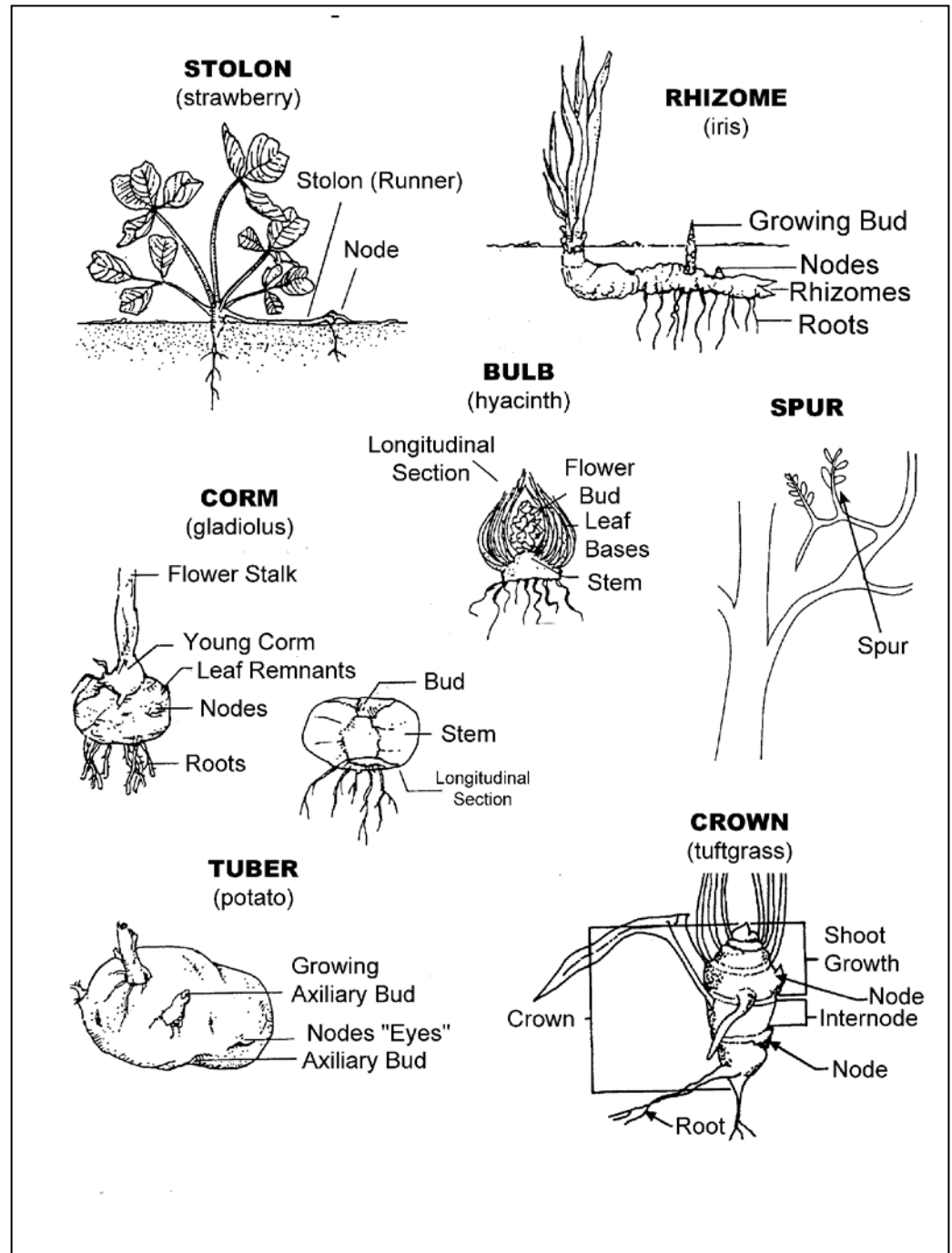

Greenhouse Operation and Management

dense stems; they are found only in some monocots such as gladiolus and crocus. The stems of *tubers* grow underground and are swollen; they can store food for plants such as yams and white potatoes. *Bulb* stems are compressed, thickened stems and have modified leaves that wrap around the stem to form the bulb. Examples of plants that grow from bulbs are onions and tulips.

The compressed stems in *crowns* are similar to those in bulbs. The leaf and flower buds grow on the crown just above the ground. Some plants produced from crown stems are asparagus and ferns. *Spurs* are short stems that form on branches of woody plants, such as pears and apple trees. *Rhizome* stems are thick and grow horizontally underground. They produce roots on the lower surface and send leaves and shoots aboveground. Iris and bamboo are examples. *Stolons*, or runners, grow horizontally aboveground, with the roots forming at the nodes. Strawberries have stolons.

Functions, Structure, and Types of Leaves

The functions of leaves are to manufacture food through photosynthesis and to protect the vegetative and floral buds. Bud scales (cataphylls) are actually modified leaves that protect buds during its dormancy, typically in winter. Juniper and mangoes are examples. Floral bracts (hyposophylls) protect flowers and the seed area while the plant develops; they may be leafy (e.g., poinsettia) or fleshy (e.g., globe artichoke). Another function of leaves is to store food. Cotyledons store food while the seed germinates and until the plant matures and begins photosynthesis.

The internal structure of the leaf is illustrated in Figure 3.7. On the upper and lower surfaces of the leaf is the epidermis, which is made up of the cuticle. The cuticle is a waxy substance covering the epidermis that protects the leaf by keeping water inside the plant. Stomata are tiny openings in the epidermis, usually found on the underside of the leaves. These pores facilitate the exchange of carbon dioxide, oxygen, and water vapor. Submerged plants, such as water lilies, do not have stomata. Guard cells surround each side of the stomata and open and close these pores in response to the amount of light or water available. If the plant does not have the necessary ingredients to produce food (sufficient light or water), the guard cells close the stomata.

The mesophyll layer is made up of palisade cells and a spongy layer. The palisade mesophyll contains vertical, elongated cells that are under the upper epidermis. Palisade cells provide strength to the leaf. Leaf cells contain chloroplasts (chlorophyll), the primary site for

Figure 3.7 - Cross-Section of a Leaf

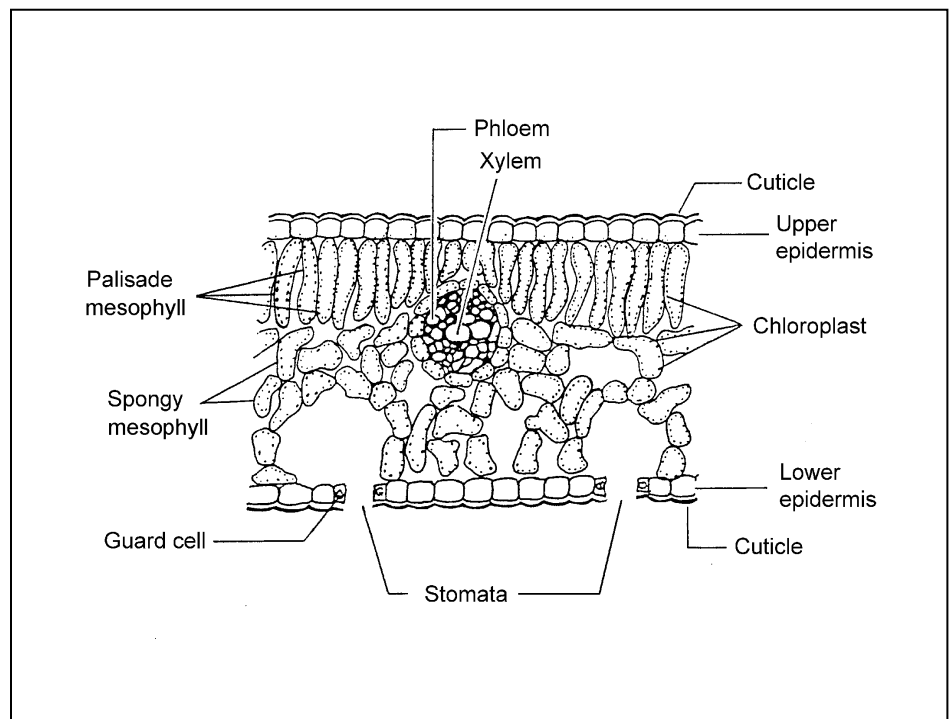

Greenhouse Operation and Management

photosynthesis. Between the palisade mesophyll and the lower epidermis is the spongy layer. It is a mass of irregularly shaped cells that has air spaces between each cell. The spongy layer gives the leaf flexibility. It also contains chloroplasts. The vascular bundle is within the spongy layer. Phloem tissues move food from photosynthesized cells to the rest of the plant. Xylem tissues move water and dissolved minerals to photosynthesized cells in leaves and the stems.

decision-making process. Figure 3.8 depicts some leaf shapes, along with their technical terminology.

Leaves can also be identified by their edges, known as “margins.” This refers to whether the outside edge of the leaf is toothed, smooth, lobed, or in a combined pattern. See Figure 3.9.

Figure 3.8 - Leaf Shapes

There are several types of modified leaves. Xeromorphic foliage (leaves adapted for plants that grow in arid conditions) has a thick-walled epidermis covered with a waxy cuticle. This protects the plants (e.g., cacti). Thorns also protect the plants (e.g., honey locusts) with short, hard leaves that have sharp points. Prickles, growing from the epidermis, can be easily removed (e.g., roses).

Tendrils are thin, stringy leaves that act as twine to support the plant (e.g., peas and grapevines). Sacs are pouchlike leaves that hold water and capture insects, such as in the Venus flytrap.

A final modification is found in submerged foliage (hydrophytes) - aquatic plants like water lilies. Both the cell walls and cuticles are thin. Because these are underwater plants, the leaves do not have to conserve moisture. The chambers in the spongy mesophyll trap internally generate gases, enabling leaves of hydrophytes to float.

Being familiar with the many sources of available plants helps the greenhouse owner select the best crops for his or her operation. Identifying various features of leaves, such as their shapes, is part of this

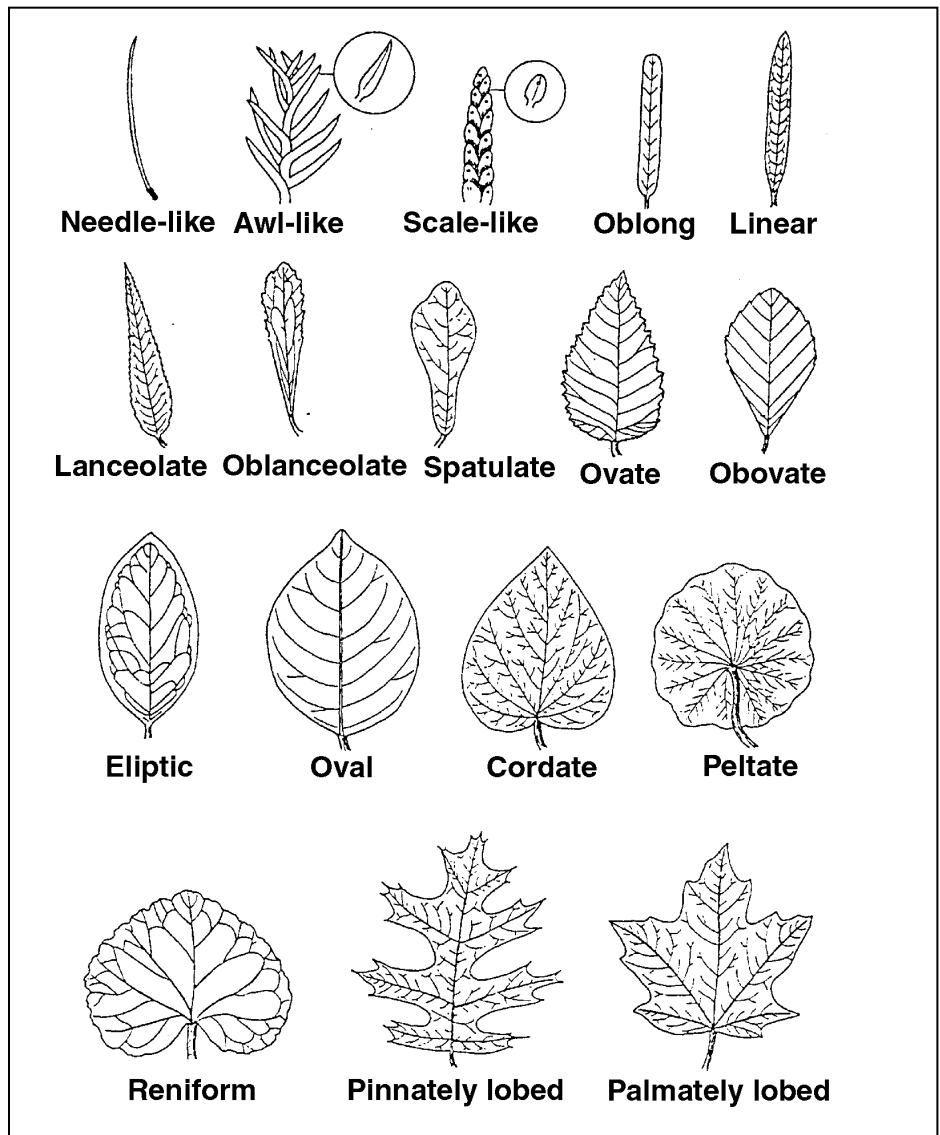
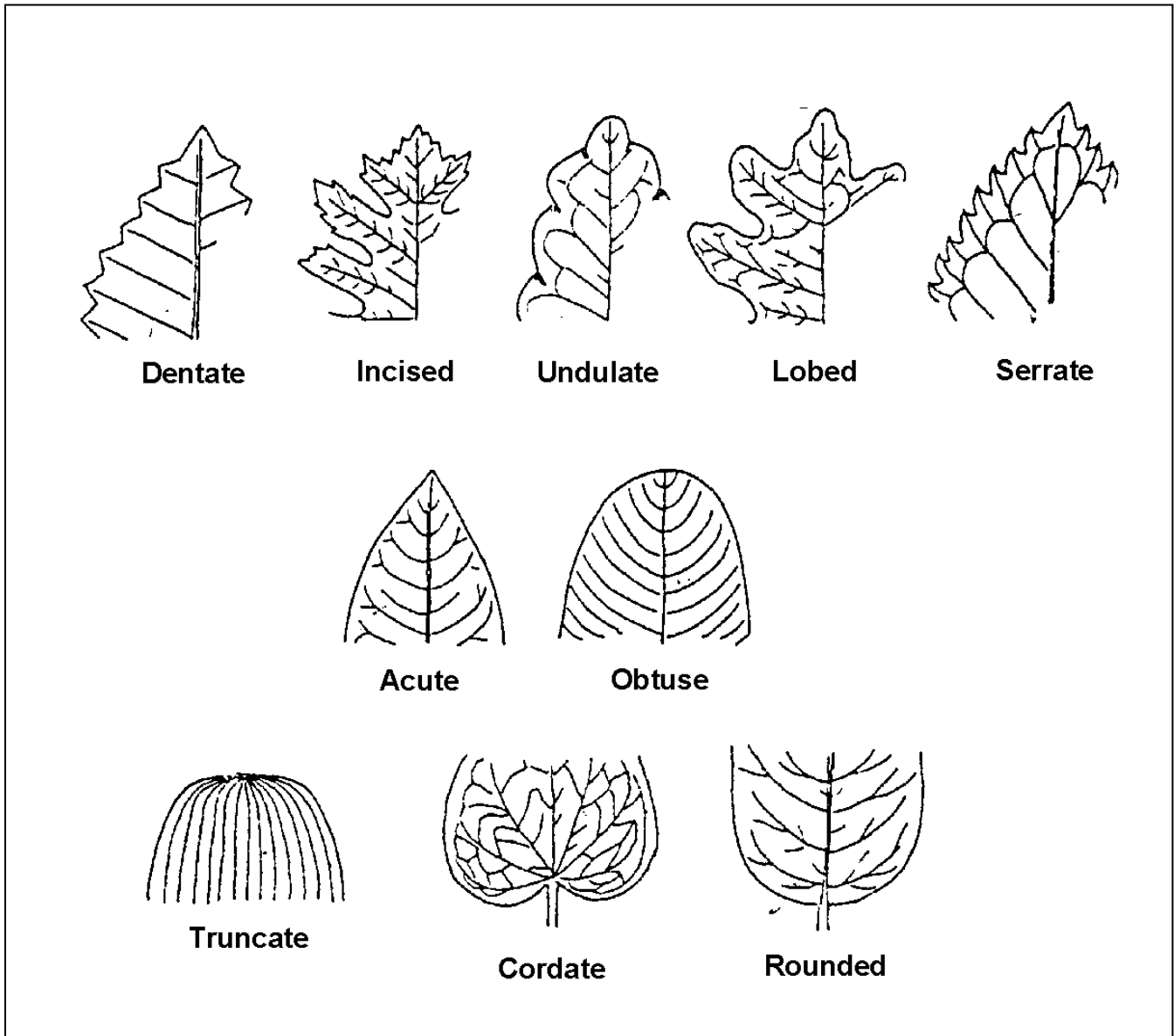

Figure 3.9 - Leaf Margins



Another factor to consider is how leaves are arranged. The three basic leaf arrangements are alternate (in a staggered pattern), opposite (in pairs), and whorl (around stem at each node). Leaves are also categorized as simple and compound. Figure 3.10 illustrates these arrangements.

Greenhouse Operation and Management

Figure 3.10 – Leaf Attachments

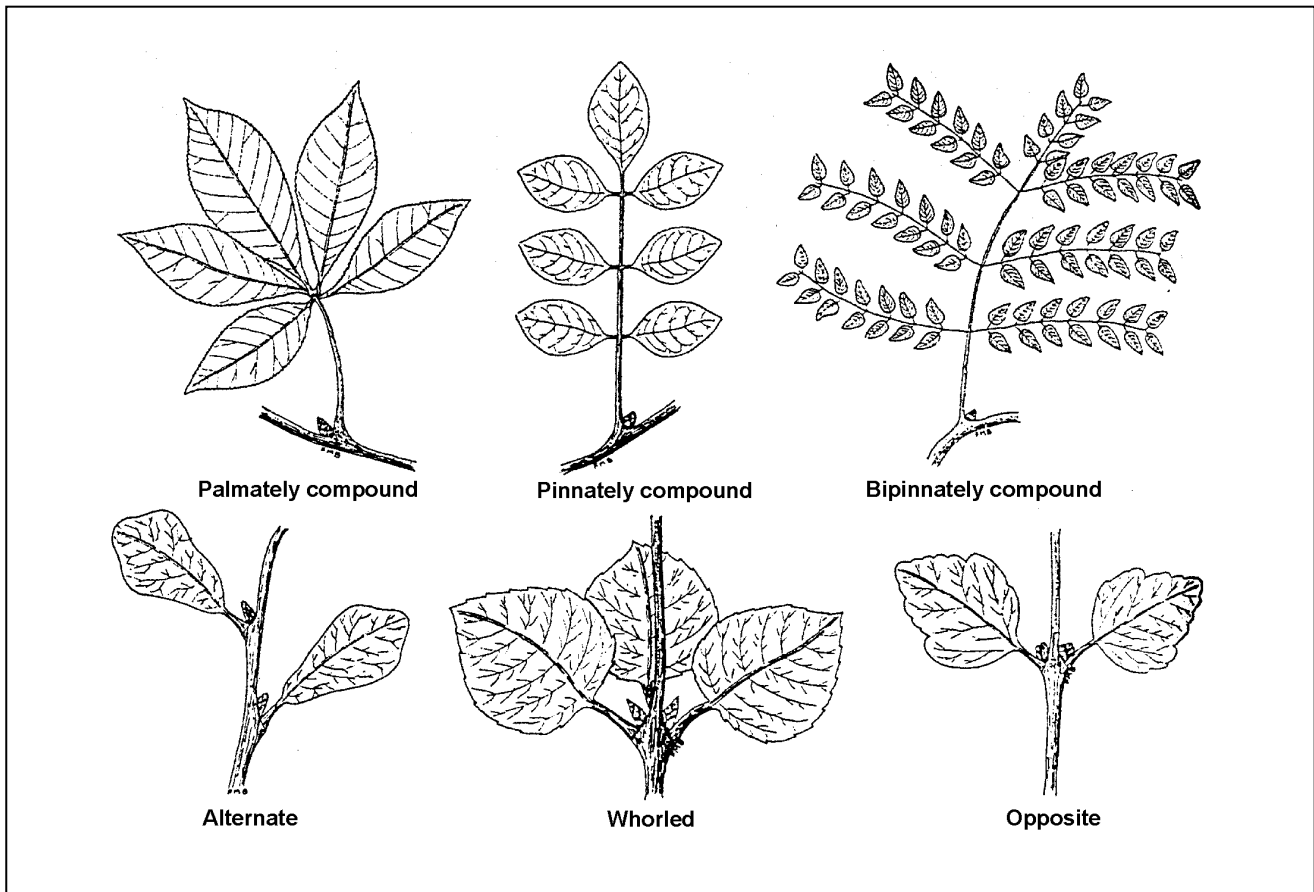

Functions, Parts, and Types of Flowers

The primary function of flowers is to produce seeds - essential for the propagation of the species- that eventually develop into fruit. The major parts of a flower are illustrated in Figure 3.11.

The *sepal* (collectively known as “calyx”) protects the emerging flower. It is the outer covering of the flower bud. Sepals protect stamens and pistils when they are in the bud stage. The *stamen* contains the male reproductive parts (androecium) of the flower and is composed of two structures: the anther that produces pollen grains and the filament that supports the anther.

The brightly colored and fragrant *petals* (collectively called “corolla”) attract pollinating

insects. Petals protect stamens and pistils in the bud stage and usually fall soon after pollination. The *pistil* contains the female reproductive parts (gynoecium): the stigma, style, and ovary. The stigma receives and contains the grains of pollen. The style connects the stigma to the ovary and supports the stigma so that it may be pollinated. Found at the bottom of the pistil, the ovary is an enlarged structure that produces ovules, which develop into seeds if they are fertilized.

The types of flowers are determined by how they grow. Flowers can grow either individually as solitary plants or as a bunch or cluster, called “inflorescence.” Three types of inflorescence are head (e.g., daisy), spike (e.g., gladiolus), and umbel (e.g., onion).

Flowers are “complete” if they contain both male and female parts with all four parts of a flower

Figure 3.11 - Parts of a Complete Flower

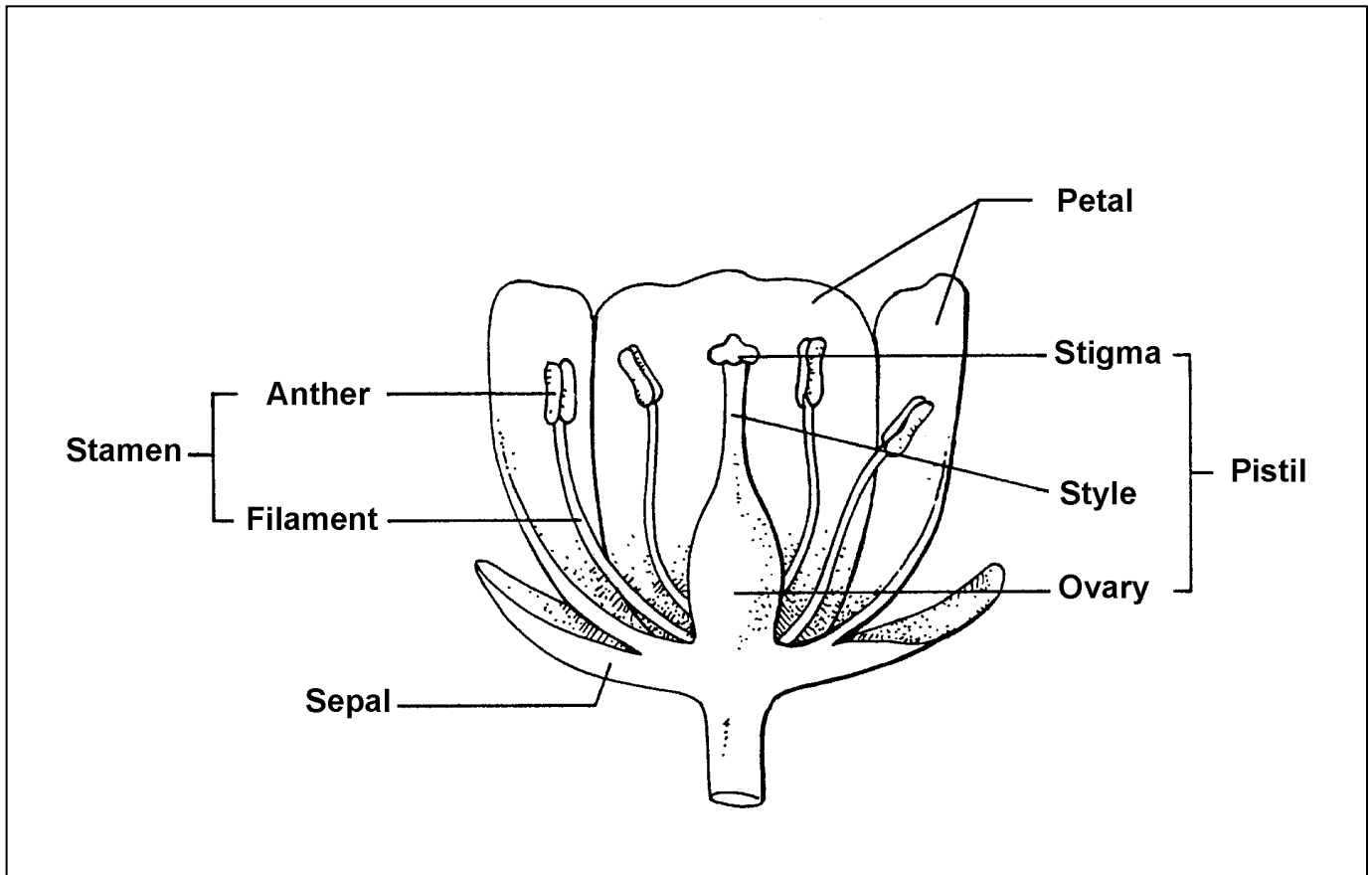

present. These flowers are usually self-pollinating. In contrast, incomplete flowers have one or more flower parts missing. The flower is either male or female and must therefore cross-pollinate.

Monoecious vs. Dioecious Plants

Monoecious plants have both male and female flowers on different parts of the same plant. Pollination can occur on the same plant, such as with cucumbers and corn. However, dioecious plants are either male or female. Pollination requires both a male and a female plant in proximity. Holly and asparagus are dioecious plants.

Summary

Understanding plant parts, structures, and functions is critical to a successful greenhouse operation. A basic study of plant anatomy can assist the greenhouse owner as he or she plans which plants to grow. This lesson described specific components of plant cells and tissues and also detailed the functions and types of seeds, roots, stems, leaves, and flowers. This information provides the basis for Lesson 2 - Plant Processes.

Credits

Acquaah, George. *Horticulture: Principles and Practices*. Upper Saddle River, NJ: Prentice Hall, 1999.

Greenhouse Operation and Management

Boodley, James W. *The Commercial Greenhouse*, 2nd ed. Albany, NY: Delmar Publishers, 1996.

Cooper, Elmer L. *Agriscience: Fundamentals & Applications*. 2nd ed. Albany, NY: Delmar Publishers, 1995.

Greenhouse Operation and Management (Student Reference). University of Missouri-Columbia: Instructional Materials Laboratory, 1990.

Herren, Ray V. and Roy L. Donahue. *The Agriculture Dictionary*. Albany, NY: Delmar Publishers Inc., 1991.

UNIT III: Plant Science Basics

Lesson 2: Plant Processes

Lesson 2 applies information from the previous lesson to the five basic life processes that plants undergo during growth: photosynthesis, respiration, absorption, translocation, and transpiration. Each of these processes is discussed below.

Photosynthesis

Photosynthesis is vital to life on Earth. It affects oxygen content in the environment, supplies food to animal life, and provides fossil fuels. The yield of more than 90% of all horticultural plants is realized through photosynthesis. Figure 3.12 illustrates the sequence of events in which a green plant uses sunlight to convert carbon dioxide and water into simple sugars, thereby releasing oxygen.

Figure 3.12 - Photosynthesis

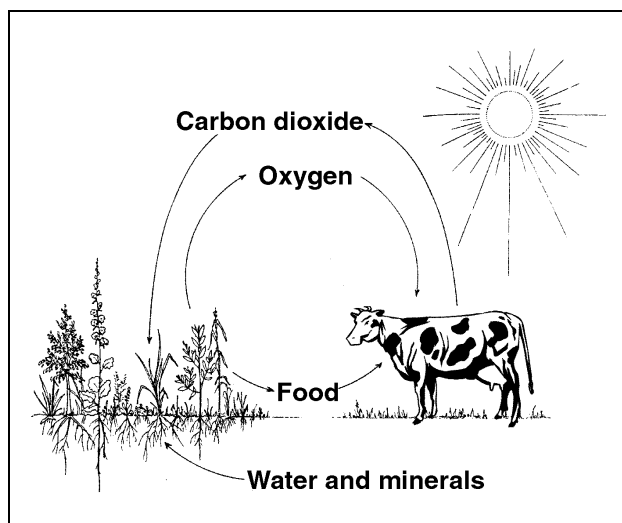

The process of photosynthesis is expressed by the following formula:

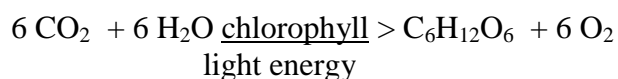

CO₂ from the air enters the plant through the stomata, which are mainly on the leaves. Hair roots absorb water from the soil; the water then moves up to the leaves via the xylem tissues. Sunlight shines upon the chlorophyll (chloroplasts) in the mesophyll cells, which are found in the stem and leaves. As a result, energy from the sun is absorbed. This triggers a chemical reaction between hydrogen in the water and carbon dioxide. Glucose, a simple sugar, is created and transported through the phloem tissues to other parts of the plant. Oxygen is then released through the stomata.

Several environmental factors affect photosynthesis. *Temperature* influences the rate at which chemical reactions occur within the plant. The optimal temperature is 65-85°F (18-27°C). High temperatures can force respiration to rise. Low temperatures delay flowering and slow growth. If the *water supply* is limited, the stomata close down. This diminishes the availability of carbon dioxide and therefore decreases the rate of photosynthesis.

Light's intensity and duration also impact photosynthesis. If the light is extremely intense, the rate of photosynthesis may decline due to a lack of CO₂. When photosynthesis occurs rapidly, plant cells consume and reduce the *amount of CO₂*. To compensate for this loss, greenhouse owners frequently use an artificial supplement called a carbon dioxide fertilizer, which is made by burning propane or methane or by using liquid CO₂.

Another important environmental factor is the plant's *photoperiod* - the length of daylight available per day. Plants grow faster with an extended exposure to light; growth slows if light is indirect and of shorter duration. A final factor

Greenhouse Operation and Management

that influences photosynthesis is the plant's *growth and development*. The rate of photosynthesis in a young, emerging leaf is typically slower than in mature leaves.

Respiration

Respiration, occurring within the plant's cells, is the reverse process of photosynthesis. Oxygen from the air is used to metabolize molecules into carbon dioxide and water. Glucose breaks down and releases energy needed for plant growth, absorption, translocation, and other metabolic processes. Respiration enables plant cells to release energy that is used in many chemical reactions within cells. Water and carbon dioxide are released into the air. Respiration does not rely on daylight; it also occurs at night. Table 3.1 summarizes the contrasts between photosynthesis and respiration.

Table 3.1 - Photosynthesis vs. Respiration

Photosynthesis	Respiration
Produces food	Uses food for plant energy
Stores energy	Releases energy
Occurs in cells with chloroplasts	Occurs in all cells
Releases oxygen	Uses oxygen
Uses water	Produces water
Uses carbon dioxide	Produces carbon dioxide
Occurs in sunlight	Occurs in sunlight and darkness

Absorption

Absorption is the process in which hair roots take up water and dissolved minerals from the growing medium through osmosis - the movement of molecules across a cell's membrane from a higher concentration to a lower concentration. Water moves from the roots and through the plant via the xylem vessels.

Translocation

During this process, water and nutrients move within the plant. Translocation occurs within the vascular system. Xylem tissues pull water upward from the roots; phloem tissues move food (glucose) from leaves to the root system and the rest of the plant

Transpiration

Through transpiration, the plant loses water primarily through evaporation from the leaf surfaces (sometimes from stems and petals). This process occurs when the stomata open to take in CO₂. Guard cells regulate transpiration. Pressure in the plant cells is reduced. Some environmental factors affecting the rate of transpiration are light, temperature, humidity, and wind. An increase in temperature accelerates the rate of transpiration, produces more carbon dioxide, and causes greater CO₂ concentration in the leaves. As a result, the stomata close at high temperatures. Low humidity slows the rate of transpiration. Wind prevents water vapor from accumulating on leaves and therefore increases transpiration.

Summary

Five processes are instrumental to plant growth: photosynthesis, respiration, absorption, translocation, and transpiration. Of all the plant processes, photosynthesis is fundamental to the survival of all living things. The remaining processes serve the plant's development by releasing energy within the cell (respiration); transporting water and dissolved minerals to the roots (absorption); moving water, dissolved minerals, and glucose within the plant (translocation); and dissipating water through evaporation (transpiration). By understanding these vital plant processes, the greenhouse owner can maximize the efficiency and productivity of the operation.

Credits

Acquaah, George. *Horticulture: Principles and Practices*. Upper Saddle River, NJ: Prentice Hall, 1999.

Cooper, Elmer L. *Agriscience: Fundamentals & Applications*, 2nd ed. Albany, NY: Delmar Publishers, 1995.

Greenhouse Operation and Management (Student Reference). University of Missouri-Columbia: Instructional Materials Laboratory, 1990.

UNIT III: Plant Science Basics

Lesson 3: Plant Classifications and Nomenclature

A rich diversity of plants is available for greenhouse operations. In deciding which crops to grow, the greenhouse owner must understand basic traits of plants and be able to identify them. Lesson 3 classifies plants according to their characteristics and purpose and explains how plants are categorized. Refer to Lesson 1 in this unit for details about plant parts, structures, and functions.

Plant Characteristics

The two aboveground stem types are herbaceous and woody. The word herbaceous is derived from “herbs,” which may be associated with aromatic plants such as oregano and basil that flavor food. In this context, however, herbaceous refers to plants that have soft, nonwoody stems. They are often green and will not survive the winter. Corn, several other vegetables, and assorted potted plants have herbaceous stems.

Woody stems are found in trees and some shrubs. As the single, main trunk in trees, the stem branches out from the upper part of the plant. As part of a shrub that does not have a trunk, the woody stem grows from the ground level. These types of trees and shrubs have secondary tissues that provide strength. Because woody stems are very tough, they can survive harsh winters. Buds of woody plants survive aboveground during the winter.

Stem growth is classified according to the stem’s position on the ground. *Climbing (creeper) stems* are vines that grow on the ground without additional support. There are three types of climbing stems. *Twining*, such as found in sweet potatoes, have stringy stems. *Adventitious roots*, found on English ivy, grow on the aerial parts of

the plant. *Tendrils* are coiling, cylindrical structures, such as found in garden peas.

Erect stems, found in trees and cultivated bushes, require no artificial support. They stand 90° to the ground and may sway slightly in response to strong winds. *Decumbent stems* (e.g., peanuts) are dramatically inclined toward the ground with the plant’s tips raised. Figure 3.13 illustrates the three modes of stem growth.

Figure 3.13. - Stem Growth

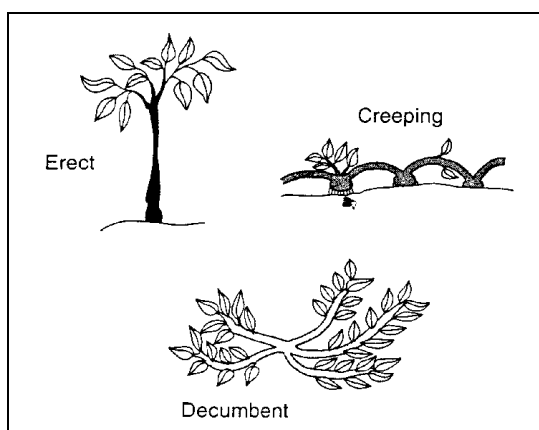

Fruit is characterized as either fleshy or dry. Fleshy fruit is soft and has internal seeds. Two major types of fleshy fruits are pomes and drupes. The ripened tissue of *pomes* (e.g., pears and apples) develops into a core; the seeds are embedded within the fruit. *Drupes* have a large, hard seed inside, called a stone, and a fairly thin outside skin. Examples of drupes are peaches, cherries, and plums. Dry fruit has one seed whose covering becomes brittle and hard when the fruit ripens. Sunflowers, peas, and nuts are dry fruits.

To accommodate the scope of the retail or wholesale operation, the greenhouse owner selects plants based upon their life cycle. *Annuals* grow quickly and complete their life cycle in 1 year.

Greenhouse Operation and Management

Most vegetables (except rhubarb, parsley, and asparagus) are annuals. Climate and season of the year are associated with two types of annuals. After the last spring frost, summer annuals (e.g., petunias, marigolds, and tomatoes) are planted and continue to grow until fall. Cold temperature and frost harm these annuals. In contrast, fall is when winter annuals are sown. These cold-tolerant plants mature during early spring. Examples of winter annuals are spinach, broccoli, and pansies. In Missouri, examples of winter annuals include kale, turnips, collards, and rutabaga.

The life cycle of *biennials* is within 2 years. Leaves, stems, and roots grow during the first year and become dormant during the winter. Flowers and fruit emerge in spring and then die. Cabbage, beets, hollyhocks, and sweet williams are common biennials that are grown as annuals in Missouri.

Perennials continue to grow from year to year. Herbaceous perennials with aboveground stems die during the winter; new leaves and shoots emerge at springtime. Woody perennials (vines, trees, or shrubs) are alive all year, but growth is slowed or enters dormancy.

Foliage refers to leaves or needles. Deciduous trees, such as maple, ash, and birch, lose their foliage. This loss may be sudden or gradual and is in response to change in temperature. Evergreens (e.g., spruce and pine trees) retain their needles throughout the year. Perennials (both herbaceous and woody) may be either deciduous or evergreen.

Another characteristic to consider is the plant's hardiness. This trait refers to how well the plant can sustain diverse environmental factors, particularly very low temperatures. A hardy plant can withstand temperature extremes; half-hardy plants tolerate moderately low temperatures but not periods of severe freezing. These plants need protection from frost. Some fruit trees (e.g., apple,

pear, peach, and cherry) can thrive in cold temperature zones such as in the Midwest and West and are considered hardy tree fruits. In contrast, tropical and subtropical fruit trees (e.g., orange and grapefruit trees) require a warm climate such as in Florida or California.

A tender plant is sensitive to extreme temperatures and cannot withstand severe frost. The seeds of tender annuals do not survive winters that have prolonged periods of below-zero temperatures.

Plant Purpose

Whether used in retail or wholesale operations, plants are grown for a particular purpose. They may be cultivated as edible crops or developed as ornamentals. Raising *edible* crops (fruits and vegetables) in an environmentally controlled greenhouse ensures steady production throughout the year. Thanks to the regulated temperature, humidity, and lighting, crops thrive and mature on an ongoing basis. This stimulates sales. Understanding the plants' traits and growth cycles helps the greenhouse owner select which edible crops will maximize production. (The next unit provides additional information about what plants need for successful development.)

Ornamentals (flowers, shrubs, and foliage plants) are grown purely for their beauty. The purpose for growing these plants is to enhance landscape, whether at home or for various businesses.

Scientific System of Classification and Naming

The science of identifying, naming, and classifying organisms is known as "taxonomy." Plant taxonomy is composed of seven basic categories, arranged from the most general to the most specific. Figure 3.14 lists this structure.

Figure 3.14 - Major Classification

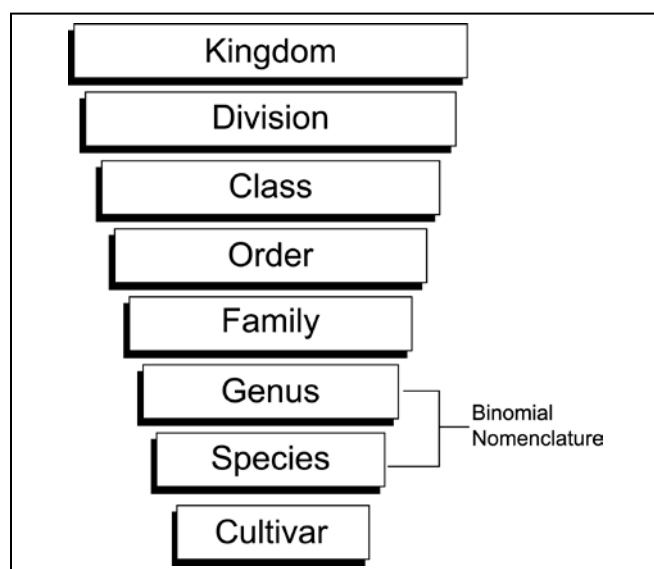

Some of the taxonomy's basic categories can be subdivided: subphylum, subclass, suborder, and subspecies. Table 3.2 lists the taxonomy of the petunia, including its subphylum.

Table 3.2 - Taxonomy of the *Petunia*

Kingdom	Plantae
Phylum	Embryophyta
Subphylum	Angiosperm
Class	Dicotyledonae
Order	Tubiflorea
Family	Solanaceae
Genus	<i>Petunia</i>
Species	<i>hybridea</i>

Botanists (plant scientists) use a binomial nomenclature (two-part name) to identify plants. Developed over 200 years ago by Swedish botanist Carolus Linnaeus, this Latin-based system gives each plant a unique name that is understood throughout the world. Binomial nomenclature creates a universal language for plant identification. No confusion arises from using multiple common names for a single plant. Binomial nomenclature is made up of the genus and species. Genus is the first part of the binomial. The first letter is capitalized and the

entire word is written in italics. It identifies the plant group that shares similar characteristics. The second part is the species name, written in all lowercase letters and italicized. The species provides additional information about the plant, such as its geographic location, origin, and physical characteristics.

A plant can be identified further by its cultivar. The word "cultivar" is a combination of the words "cultivated" and "variety." Botanists and agronomists (specialists in soils and crop sciences) develop the cultivar; it does not originate naturally in the wild. A cultivar is a subcategory within the species. Hybridization occurs among cultivars of the same species. To indicate a cultivar, the word is usually capitalized and written with single quotation marks or is preceded by the abbreviation "cv." In the sample taxonomy above, the cv is 'Blue Moon'.

Summary

By learning key characteristics of plants, the greenhouse owner can determine which plants are suited for his or her operation. Stem types, stem growth, type of fruit, life cycle, foliage, and hardiness are specific traits that affect the owner's decision. Another factor to consider is whether the plants are used as edible crops or as ornamentals. In order to communicate effectively with other horticulturists, the greenhouse owner must be able to identify each plant without causing confusion. This is accomplished by understanding how plants are categorized and named and by using binomial nomenclature. All individuals who work with plants understand this two-part, Latin-based naming system.

Greenhouse Operation and Management

Credits

Acquaah, George. *Horticulture: Principles and Practices*. Upper Saddle River, NJ: Prentice Hall, 1999.

Cooper, Elmer L. *Agriscience: Fundamentals & Applications*, 2nd ed. Albany, NY: Delmar Publishers, 1995.

“Fruit Types.”
<<http://www.resnet.wm.edu/~mcmath/bio205/fruits.html>> accessed 2/4/02.

Gerrish, Jim. “Winter Annual Forages.” Missouri Agricultural Experiment Station, MU College of Agriculture, Food and Natural Resources.
<<http://aes.missouri.edu/fsrc/news/archives/n100v9n4a.stm>> accessed 5/10/02.

Herren, Ray V. and Roy L. Donahue. *The Agriculture Dictionary*. Albany, NY: Delmar Publishers Inc., 1991.

Lee, Jasper S., Series Editor. *Introduction to Horticulture: Science and Technology*, 2nd ed. Danville, IL: Interstate Publishers, Inc., 1997.

Unit IV: Plant Growth

Lesson 1: Environmental Effects

This unit discusses five aspects of plant growth. Lesson 1 examines the environmental effects of light, temperature, indoor gases, and air quality on plants grown in a greenhouse. Also discussed are plant processes that were detailed in Unit III, Lesson 2. The remaining lessons describe the effect of growing media, irrigation, nutrients, and fertilizer on plant growth.

Light in the Greenhouse

To successfully grow plants in a greenhouse, sufficient light must be available for photosynthesis to occur. Typically, indoor plants require a high concentration of light, but this depends on the species. Greenhouse crops get their source of light either directly from the sun (solar heating) or artificially through high-intensity-discharge (HID) lamps. The advantage of lamps is that they provide light during winter and on cloudy days, and they extend the length of “daylight” for the plants. HID lamps in particular are the most efficient type of supplemental lighting in greenhouses because 27% of the electrical energy is converted to light. These lamps are available in various power ratings. If correctly spaced in the greenhouse, they provide 600-1,000 foot-candles of light (explained below) for a reasonable price.

Light is broadly characterized by its intensity, duration, and quality, as explained below.

Light Intensity

Light intensity refers to brightness and quantity; it is measured in foot-candles (f.c.). One foot-candle equals the amount of light that hits a surface 1 foot away from a standard wax candle. At noon on a clear sunny day, the f.c. value is 10,000. Plants vary in how much light intensity they need,

as summarized in Table 4.1. Tropical foliage plants, impatiens, African violets, and ferns favor low f.c. levels, whereas lilies, roses, geraniums thrive at high f.c. levels.

Table 4.1 - Light Intensity Requirements of Plants as Measured in Foot-Candles

Plants' Required Light Intensity	Foot-Candles
Low	500-1,250
Medium	1,250-2,500
High	More than 2,500

Time of day, location of the window, and season of the year determine the level of light intensity in a greenhouse. The sun's intensity is greatest at noon. By about 10 a.m. and again at 4 p.m., the longest shadows are cast, so light is less intense. Plants near a southern window receive prolonged exposure to light. A northern exposure offers less light. Because the sun is closer to the Earth during the summer, the light is more intense. During the winter, less direct light is available.

A sufficient amount of light intensity enhances photosynthesis and promotes growth. A healthy plant has thick stems, increased height, a developed leaf area, plentiful roots and flowers, large flowers, rich pigment, and short internodes. (Internodes are parts of the stem or other plant parts that are located between two nodes.) But any extremes in light intensity affect whether plants can thrive in the greenhouse.

If the light intensity is too low, photosynthesis diminishes. This stunts the plant's growth and creates long internodes that weaken the stems. Flowering is delayed or may stop completely. There is less pigment and leaf area. If light shines on just one side of the plant, the plant bends

Greenhouse Operation and Management

toward the source of light (phototropism). Its stems also curve to the light, but the roots turn away.

If light intensity is more than 2,500 f.c., it exceeds the plant's photosynthetic requirements. This accelerates respiration within the cells. As a result, the available food supply (glucose) is substantially depleted. Consequently, the plant's growth is stunted. Typical adverse effects are reduced pigment, small leaves and flowers, and scorched or dried leaves and flowers. In addition, the flowers become yellow and bleached.

Light Duration

The amount of light received throughout the day - the photoperiod - affects the plant's growth rate. As stated in the previous unit, plant growth results from photosynthesis; photosynthesis occurs only in the presence of light. Light duration and light intensity are interrelated. The quantity of available light varies with the greenhouse's latitude and the season of the year. As indicated above, during the summer, light is more intense. The days are long and the nights are short. The photoperiod for summertime plants is long. The reverse is true for plants cultivated during winter: the days are short and nights are long.

The greenhouse owner can increase light duration by using artificial lights and decrease the amount of light by placing dark cloths over the growing structure or above the crop

Plants react to the length and timing of light and darkness (photoperiodic responses) during their major developmental stages: flower bud initiation, bulb and tuber formation, bract coloration, and plantlet formation. Flowering plants are categorized into four types based on their photoperiodic responses: short day (long night), long day (short night), intermediate day, and day neutral. These responses measure the duration of *darkness* rather than the amount of light the plant receives.

Each type of plant has a certain "critical period" during which it must receive a specific amount of darkness. During this time, plants are also exposed to brief interruptions of light. The most effective time for this "pulse" of light to occur is midway through the period of darkness. Each species has a specific time when this pulse of light is advantageous to its growth cycle.

Under continuous light, short-day (long-night), plants (e.g., poinsettias) do not bloom. A very precise, limited amount of light is required. Long-day (short-night) plants (e.g., asters) typically flower in the summer. Dahlias, another example, produce the desired flowers, not tubers, when nights are short. Intermediate-day plants, such as certain grasses, do not bloom if the days are either too short or too long. A final category, day-neutral plants, responds only to the developmental needs of the plant, not to the photoperiod. Corn, cucumbers, and tomatoes belong in this group.

Light Quality

Quality of light refers to the spectrum of color - wavelength - as measured in nanometers (nm). Figure 4.1 shows the wavelength of light with respective nanometer values and the corresponding rays for each band of color. The sequence of the colors is determined by the wavelength of light. Wavelengths longer than red are called "infrared"; wavelengths shorter than violet are "ultraviolet."

Figure 4.1 - Radiant Light Spectrum

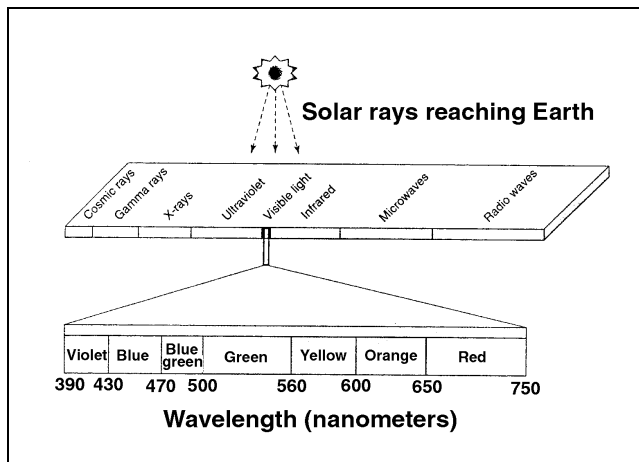

Ultraviolet (UV) light has a very short wavelength and is invisible. UV light is very damaging; excessive levels stifle photosynthesis and injure parts of the plant. Plants grown in high altitudes receive too much UV radiation; as a result, their growth is stunted. Installing appropriate coverings that screen out damaging rays compensates for excessive UV light.

White (visible) light is actually a combination of all the colors in the spectrum. Photosynthesis uses only selected wavelengths.

If plants are grown only under blue light, photosynthetic activity is extremely high. The plants are shorter, darker, and have hardened tissues. Blue light stimulates stem length and strength, increased branching, and color in the leaves and flowers.

The wavelength of green light provides very low photosynthetic activity. This is because chlorophyll - a green pigment essential to photosynthesis - *absorbs* all visible wavelengths except green. Green is *reflected* and thus is easily detected.

Red light provides very high photosynthetic activity. Plants grow readily, stems elongate, and seeds germinate rapidly. In addition, red light is

the most effective wavelength for interrupting the critical period in long-day plants.

Far-red light (higher nanometer value than red light) promotes flowering in short-day plants and inhibits flowering of long-day plants. Infrared light is invisible. Its heat causes overheating within plant cells; consequently, the stomata close and photosynthesis ceases.

Temperature

Each plant's ability to grow depends on specific temperature levels. If the temperature is below the minimum level, growth slows, flowering is delayed, and the color of leaves and flowers intensifies. If the temperature is above the maximum level, general growth is inhibited and causes premature smaller flowers, smaller leaves, reduced stem diameters, and diminished coloring. The optimum temperature is the level at which growth is the greatest. Temperature also influences the developmental processes described below.

Seed germination is greatly affected by temperature. Typically, the optimum air temperature is 60-70°F (15-21°C). Heating the bottom of the benches that support the plants increases the rate of germination. Each crop varies in its heat requirements for germination. The greenhouse owner can maximize the operation by identifying the correct temperature for each crop.

Temperature is an important factor in photosynthesis. The minimum temperature varies among plant species. The maximum temperature is usually 95°F (35°C). The growth rate increases as the temperature rises until 95°F is reached. When the temperature exceeds 95°F, the growth rate drops quickly and then stops completely because enzymes are deactivated. (Enzymes are large, complex proteins that activate chemical reactions within cells.) The optimum temperature in most plants is 50-75°F (10-24°C).

Greenhouse Operation and Management

Other plant processes respond to temperature. Respiration increases with the rise of temperature. This depletes the food supply needed to fuel cellular metabolism. At extremely low temperatures (32-34°F) (0-1°C), the respiration rate slows enough to keep plants, cut flowers, fruits, and vegetables fresh for extended periods. This gives the greenhouse owner more time to display crops in retail operations.

The rate of transpiration increases as the temperature of the leaf rises. The leaves are sensitive to warm or cold air currents and drafts, cold air radiating from the greenhouse's sides on cold nights, and condensation (moisture on leaves that is colder than the air).

Gaseous Elements

Several gases found inside the greenhouse affect plant growth. *Oxygen* is essential for plant respiration. Adequate amounts occur naturally. *Carbon dioxide* is a key ingredient in photosynthesis. CO₂ promotes plant growth and flowering. Through plant respiration and the decay of organic matter, sufficient amounts of CO₂ occur naturally in the greenhouse. However, if the fans are turned off, hindering air circulation, the amount of CO₂ is limited. The greenhouse owner can adjust inadequate levels of CO₂ by installing a CO₂ generator. (Refer to Unit II, Lesson 2.)

Water vapor (humidity) is also important to the greenhouse's internal climate. The optimum relative humidity (RH) in most greenhouses is 45-85%. High RH (over 85%) promotes fungal diseases; low RH can increase transpiration and stunt plant growth. Low RH produces shorter plants, fewer new shoots, less leaf growth, smaller flowers, and stiff upright stems. The greenhouse owner can increase the relative humidity by installing a humidifier and placing trays of water under the benches.

The greenhouse may contain detrimental air pollutants that impair plant growth and crop yield and also harm personnel. Some of these harmful gases are listed in Table 4.2.

Table 4.2 - Greenhouse Air Pollutants

Air Pollutants
Ammonia
Asbestos
Chlorine
Ethylene
Fluoride
Mercury
Natural gas
Nitrogen dioxide
Peroxyacetyl nitrate
Pesticides
Sulfur dioxide
Wood preservatives

Soil with organic matter that is pasteurized through steam releases ammonia, which is detrimental to plants. Asbestos particles suspended in the air damage the lungs. Any ceiling tiles or building materials containing asbestos should be replaced. If released from an aerosol can, chlorine and fluorine destroy ozones. (Ozone is a form of oxygen found above the Earth's surface that filters out harmful ultraviolet rays.)

Ethylene is a toxic gas found most often in greenhouses. It is produced when exhaust gases from unit heaters accumulate but cannot escape. Greenhouses heated with natural gas also produce pollution. Both of these pollutants can be eliminated with an ample exchange of outside air into the greenhouse. Mercury is found in various control devices in the greenhouse, e.g., high-intensity-discharge lamps. If such a device breaks and the mercury spreads over the floor, contamination may occur.

Nitrogen dioxide from outside automobile exhaust fumes can adversely affect greenhouse-grown

plants if there is improper ventilation. Pesticides intended to rid plants of diseases may be toxic if excessive and concentrated amounts are applied. Wood preservatives containing creosote and pentachlorophenol are also toxic to plants.

Summary

Light, temperature, gaseous elements, and air quality are environmental factors that influence plant growth within the greenhouse. Identifying plants' unique environmental requirements and devising specific approaches to meet them help ensure healthier and more profitable crops for the greenhouse owner.

Credits

Acquaah, George. *Horticulture: Principles and Practices*. Upper Saddle River, NJ: Prentice Hall, 1999.

Boodley, James W. *The Commercial Greenhouse*, 2nd ed. Albany, NY: Delmar Publishers, 1996.

Cooper, Elmer L. *Agriscience: Fundamentals & Applications*. 2nd ed. Albany, NY: Delmar Publishers, 1995.

Farabee, M.J. "Photosynthesis." <<http://gened.emc.maricopa.edu/bio/bio181/BIOBK/BioBookPS.html>> accessed 2/1/02.

Greenhouse Operation and Management (Student Reference). University of Missouri-Columbia: Instructional Materials Laboratory, 1990.

Herren, Ray V. and Roy L. Donahue. *The Agriculture Dictionary*. Albany, NY: Delmar Publishers Inc., 1991.

Koning, Ross E. "Light Relations." *Plant Physiology Website*. 1994. <http://koning.ecsu.ctstateu.edu/plants_human/light.html> accessed 1/31/02.

"Photoperiodism and Phytochrome." <<http://www.ultranet.com/~jkimball/BiologyPages/P/Photoperiodism.html>> accessed 1/31/02.

"Radiant Energy." <<http://www.ultranet.com/~jkimball/BiologyPages/R/RadiantEnergy.html>> accessed 1/31/02.

"Seed Germination." <http://149.152.32.5/Plant_Physiology/Seedgerm.htm> accessed 1/31/02.

"The Study of Biological Rhythms - Photoperiodism." <<http://www.mrs.umn.edu/~goochv/BioRhyt/Lectures/photoperiodism/photoperiodism.html>> accessed 1/31/02.

Unit IV: Plant Growth

Lesson 2: Growing Media and Containers

Growing media - the materials in which plants are cultivated - are fundamental to successful crop production. Plants depend upon soil-based media or specialized mixtures (“soilless” media) for development. This lesson focuses on the importance of growing media and highlights the qualities of soilless mixes. Information about types and materials of growing containers is also presented.

Importance of Growing Media

As the material in which plants grow, the growing medium provides essential nutrients to the roots by absorbing minerals and water. Its key functions are to secure the roots so the plant is upright and to facilitate the exchange of oxygen and CO₂, required for plant growth. In order to promote growth, the medium should hold enough water at the roots (water-holding capacity) and be able to drain properly.

Loose, well-aerated medium results when there is enough air space at the roots. This is known as “porosity”: tiny openings (pore spaces) between solid particles. The total amount of pore space determines how well the growing medium can retain air and water. Levels of available oxygen are a function of porosity: inadequate pore space means that a shortage of oxygen develops when too much water is supplied. The size and distribution of individual pores determine the rate of gas exchange and drainage. This influences the effectiveness of the growing medium. The ideal medium has a mixture of large and small pore spaces.

The growing medium’s temperature impacts the activity of microorganisms (e.g., soil bacteria, fungi, insects) and the absorption rate of water and fertilizer. When the temperature ranges from

above 32°F (0°C) to slightly over 110°F (44°C), the greatest amount of activity occurs. At that point, microorganisms convert organic nitrogen fertilizers in the soil to forms that can be readily absorbed. (See Lesson 5 in this unit.)

Desirable features in the growing medium are that it be loose and well aerated, have a suitable pH level and cation exchange capacity, and drain well. (These chemical characteristics are discussed in further detail below.) The medium should be able to hold enough water for plant growth and be free of unwanted seeds, weeds, insects, and pathogens.

Physical characteristics of the growing medium are composition, texture, and structure. The *composition* of an ideal soil-based growing medium is 45% minerals, 5% organic matter, 25% water, and 25% air (pore spaces), as seen in Figure 4.2. Actual field soil can be amended so that it achieves this composition. (Refer to the section on pasteurization.)

Figure 4.2 - Composition of Soil-Based Growing Medium

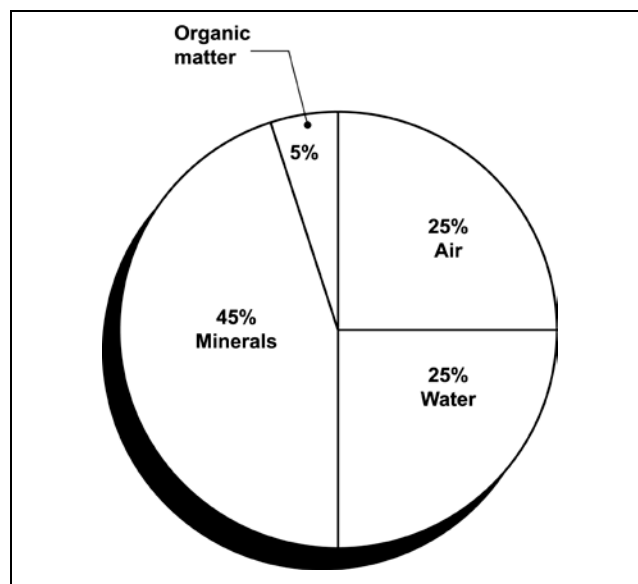

Greenhouse Operation and Management

The mineral components of naturally occurring soil are sand, silt, and clay. Sand is the largest particle. Silt particles, formed by water breaking down minerals, are smaller than sand. Clay, the smallest particle, fills the gaps between the other particles. Organic matter is made up of decayed plant and animal residue. The air portion of soil is made up of oxygen, carbon, and hydrogen.

Soil *texture* refers to the size, distribution, and proportion of sand, silt, and clay particles. Water retention and air porosity are related to the soil's texture. Soil containing mostly sand (large particles) is composed of large pores. Soil with a majority of small, finely textured particles (clay) has small pores that resist the flow of water and therefore increase the soil's water-holding capacity.

If the soil contains equal amounts of all three particles, it is a "loam." However, pure loam is not found in the field. Usually, one of the mineral particles predominates. Soils are therefore identified according to the proportion of mineral content: "sandy clay," "silty clay loam," etc. The classification of various soil types is depicted in a triangle, as shown in Figure 4.3. The combination of particles determines whether the soil texture is fine, medium, or coarse.

Figure 4.3 - Soil Texture Triangle

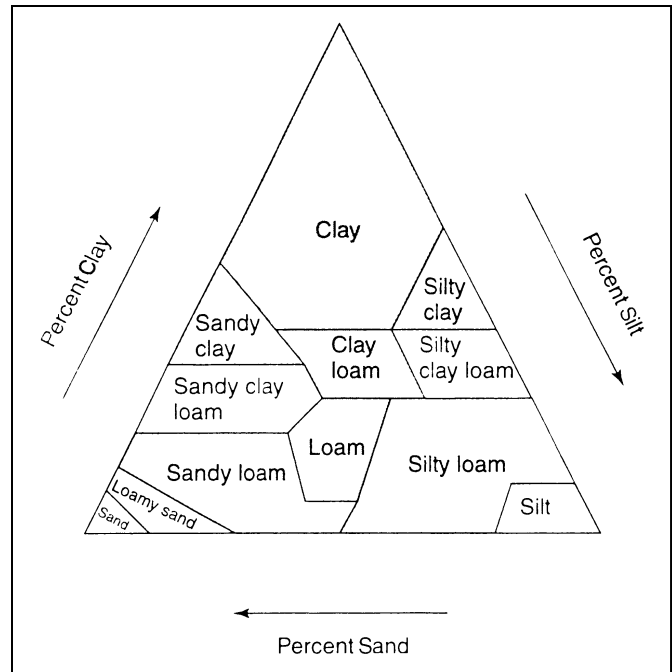

Soil structure refers to how the three types of particles are combined and arranged. This factor affects water-holding capacity, porosity, soil's ability to transmit water into the plant (permeability), and the rate of water absorption into the roots (infiltration). An aggregate of sand particles promotes drainage. However, soil with too much sand does not hold moisture. A combination of mostly clay particles retains water and keeps the soil moist. But too much clay hardens the soil surface, preventing needed drainage. Rearranging the soil's structure alters its texture. The amount of these three particles can be changed until the desired result is achieved. Adding organic matter, for example, improves soil structure because it increases pore space.

Two important chemical characteristics of the growing medium are pH and cation exchange capacity (CEC). A soil's *pH* measures the level of alkalinity or acidity and ranges from 0 to 14. A value of 7 is neutral; above 7 is alkaline (base); below 7 is acidic. See Figure 4.4

Figure 4.4 - pH Scale

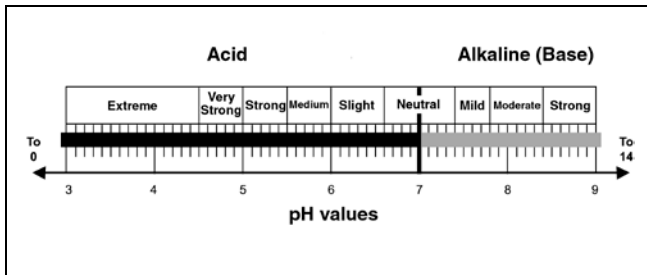

The pH is the concentration of the hydrogen ion: an electron with an electrical charge. It determines whether the soil can receive nutrients. The pH for most soils ranges from 4.0 to 8.5. Most greenhouse crops need a pH level ranging from 5.5 to 6.5. The pH of the greenhouse's growing medium ranges in levels of acidity and alkalinity. Different plants thrive in various levels of acidity. For example, the color of a hydrangea differs with the type of soil: it is pink in acidic soil and blue in alkaline soil.

In soil with a high pH (alkaline), many nutrients separate from their solution, depriving the plant of sustenance. Nutrients in acidic soil may become overly concentrated and harmful to the plant. The growing medium's pH level must suit the needs of each plant.

Cation exchange capacity (CEC) measures the soil's ability to hold nutrients; it gauges soil fertility. Fertile soil attracts and retains essential nutrients, promoting plant growth. A cation is a positively charged ion in a solution. The soil's clay, silt, and organic particles have negative charges that attract and hold cations. A clay particle in soil has a large surface area, making the cation's absorption more efficient. The amount of exchangeable cations is expressed in milliequivalents (meq) per 100 grams (g) of soil at pH 7 (neutral). For greenhouse media, the best CEC level is 6-15 meq/100 g.

Pasteurizing Field Soil

For greenhouse plants, using just field soil is inefficient and ineffective. The texture of outdoor, naturally occurring soil tends to be dense and bulky; therefore, it drains poorly and does not aerate properly. The nutrients in field soil vary in quantity and quality, making precise duplication difficult. The soil may also contain weeds, insects, excessive amounts of pesticides, or diseases that can harm the growing plant. Another drawback is that hauling soil from the field into the greenhouse is heavy work and can be quite expensive.

However, field soil can be used to cultivate greenhouse plants if it is amended to create the desired characteristics. This change is accomplished through pasteurization, a process whereby only harmful organisms are killed. The goal is to kill as many weed seeds as possible and to destroy all pathogenic bacteria and fungi. During pasteurization, organisms that are beneficial to plant growth are not eliminated.

The three methods of pasteurization are steam, chemical, and electrical. *Steam* pasteurization applies heat to the soil. The soil must be thoroughly mixed after steaming. (Fertilizers cannot be pasteurized; they should be added after steaming.) Air is introduced into the steam and administered at 140°F (60°C) for 30 minutes. It is important to regulate the temperature. Excessively high temperatures kill the beneficial organisms that destroy the disease-causing organisms and would increase the level of toxic substances in the soil. Steam pasteurization allows planting to resume as soon as the soil cools. Another advantage is that this method increases drainage and aerates the soil because the heat causes the small soil particles to stick together. It is also an inexpensive process.

Chemical pasteurization, less effective than steam, produces highly toxic fumes. In some cases, all workers and plants must clear the area for 24

Greenhouse Operation and Management

hours to several weeks. The gases used during this process are effective only if the soil is the correct temperature, which depends on the chemical used. Some of the chemicals used include chloropicrin (tear gas), which attacks weed seeds, fungi, and nematodes (tiny round worms that attack plant roots); and basamid (DMTT). The soil should be 60°F (15.5°C) or warmer, preferably 70°F (21°C). All crops must be removed from the greenhouse.

After application, the soil needs 10-21 days' exposure to fresh air before it can be used for planting. Individuals applying chloropicrin should wear airtight masks to avoid inhalation. Vapam, applied between 50°F (10°C) and 90°F (21°C), also kills weeds, fungi, and nematodes and requires removing all plants from the greenhouse. In order for vapam to spread evenly throughout the soil, it must be watered thoroughly. The treated soil needs 2-3 weeks of fresh air before planting can resume.

It is important to note that chemical pasteurization has the potential to endanger the environment. Greenhouse owners should stay up-to-date on acceptable usage of chemical fumigants.

Electrical pasteurization, typically not used in commercial greenhouses, handles only small amounts of soil. It is neither an efficient nor a cost-effective process.

Disinfecting tools, used pots and flats, plant supports, and benches can prevent contamination inside the greenhouse. Steaming clay and wooden containers rids these items of pathogens. Plastic pots, however, should be fumigated with appropriate chemicals. The shoes of anyone entering the greenhouse can spread pathogenic soil, thereby endangering the growing plants. Standing on the benches must be forbidden. Another useful policy is placing a fiber mat inside a shallow tray filled with a disinfectant solution and requiring people to wipe off their shoes on the mat.

Advantages of Soilless Growing Medium

As the name indicates, soilless growing medium contains no naturally occurring field soil. It is preferred for use in greenhouse operations for several reasons. It is lightweight, making shipping inexpensive. Its capacity for drainage and porosity prevents roots from rotting. Because its composition is consistent, reproducing uniform amounts of high-quality mixtures is easy and efficient. Soilless medium is also free of unwanted seeds, weeds, insects, and pathogens. The greenhouse owner can buy ready-to-use bags of soilless medium or custom mix the medium as needed for individual plants. As a nonreactive (inert) medium, it contains very low amounts of nutrients. Soilless growing medium does not require pasteurization because during manufacturing, the elements are processed at very high temperatures.

Ingredients in Soilless Mixes and Soil Amendments

Soilless mixes are composed of organic elements and mineral soil amendments. Organic materials provide beneficial ingredients to the media. Rich in nutrients, they improve the soil's physical structure. In addition, organic matter increases the medium's water-holding capacity, aeration, drainage, and cation exchange.

Organic soilless mixes are composed of peat, wood residues, and coir. *Peat* is made from peat moss, sphagnum moss, humus, decomposed plants, and decayed animal residue. Fibrous peat moss can hold 15-20 times its weight in water. This water-holding capacity is further enhanced by adding perlite and vermiculite (discussed below) as well as other materials. Peat moss also is valuable because it has ample quantities of pore space that hold air and water essential for plant growth. By total volume, the porosity of peat moss is 85-98%. (For greenhouse-grown plants, the desired total pore space by volume is not less than 50%.)

Greenhouse Operation and Management

Sphagnum moss peat is fairly acidic, but adding finely crushed limestone adjusts the pH level. Another component is humus, which is decomposed organic matter. Rich in nutrients, as humus decays it releases nitrogen, sulfur, phosphorous, and carbon dioxide into the soil. As CO₂ is released, it combines with water and creates weak acids in the soil that break down other minerals. (The nutrients found in minerals are detailed in Lesson 4 of this unit.)

Additional ingredients of soilless media may include decomposed plants (e.g., rotted leaves) and decayed animal matter (e.g., manure), but if contaminated or overly concentrated, these additions to the medium would require pasteurization to be usable.

Wood residues are by-products of the lumber industry and are valuable amendments of soilless media. Although wood loses nitrogen through decomposition, supplementary applications of nitrogen make wood residues a productive addition to the growing medium. Leaf mold from maple, sycamore, and oak improves drainage, aeration, and water-holding properties of the medium. Composted sawdust also may be added but caution is required. If it is obtained directly from the sawmill, high levels of nitrogen must be supplied; these levels must be stabilized before incorporating the sawdust into the medium. Another issue is that the medium's pH may change. Finally, cedar and walnut trees produce toxins in the sawdust. Bark from hardwoods (e.g., oak and maple) and softwoods (e.g., pine trees) contribute nutrients to the medium. However, just as with sawdust, care is advised. Certain trees (e.g., walnut and cherry) contain toxins that inhibit growth.

Coir is the fibrous outer layer of the coconut husk, a by-product of the coconut industry. Thanks to its excellent air porosity and water retention, coir helps the growing medium absorb moisture easily and drain quickly.

Mineral (inorganic) materials offer several advantages to the growing medium. They improve the physical structure of soil-based media and increase aeration and drainage. Four types of inorganic materials are usually found in soilless mixes. *Sand* is finely ground stone; the type used with growing media comes from mountain rocks. Thanks to its large particle size, sand provides good porosity and aeration by admitting large quantities of air into the growing medium. It promotes drainage but cannot hold sufficient quantities of water for the emerging plant. Its weight can support the growing plant.

Perlite (volcanic rock) expands and becomes porous when heated to approximately 1,800°F (982°C). It has a neutral pH, holds three to four times its weight in water, and improves drainage and aeration. Although it is low in nutrients, perlite is ideal as a seed-germinating medium for rooting cuttings

Vermiculite (mica compound) when heated to about 1,400°F (760°C) develops a layered structure that helps retain water and fertilizer. When moist, vermiculite does not expand, thereby reducing its water-holding capacity. It absorbs fertilizer and contains sources of magnesium and potassium that the plants can access through their roots. Horticultural vermiculite comes in a range of sizes suitable for various plants. However, in its raw form, vermiculite can contain hazardous dust that is harmful to greenhouse personnel.

Calcined clay, heated to 1,300°F (704°C), forms heavy, porous particles made up of many smaller water-holding pores. The clay's high cation exchange capacity indicates that nutrients are retained in the medium. This specialized clay also adds volume to the medium and improves the soil structure.

Other materials may be used in soilless media. *Polystyrene foam* (a by-product of Styrofoam in beads or flakes) is light and improves aeration. It does not absorb water and has a low pH. Its CEC

Greenhouse Operation and Management

is low. *Rock wool* is formed when a mixture of basalt, coke, and limestone is melted at 2,700-2,900°F (1,482-1,600°C). Its water-holding capacity is great: it holds 3-4% solid matter and 96-97% pore space. When saturated, it drains 15-17%, which promotes root growth. But rock wool deteriorates very slowly and is not biodegradable. As a result, the question of responsible disposal arises. Environmental agencies of several countries forbid dumping rock wool in landfills. Whether its use in the United States will persist is currently not known; the greenhouse owner should stay apprised of any regulatory changes.

Selecting Growing Containers

When selecting growing containers, the greenhouse owner considers how the plant grows: its height, width, shape, and requirements for root space. Another factor is the intended market. Retail operations generally use larger pots than wholesale businesses.

Basic Types of Containers

Various types of containers are available for specific purposes. (The next section describes the

composition and differentiating features of the materials used for plant containers.) Rooting containers are usually made from peat, an organic material. *Peat pots* are filled with growing media.

Peat pellets are self-contained growing units that expand when watered. Seeds and cuttings are pressed directly into the pellet; no additional growing medium is required. When the plant develops, the pellet is transplanted into the soil. *Peat strips* are containers made up of 6-12 square peat pots that are joined together, forming an individual unit. Plants are grown in each pot. Figure 4.5 illustrates three types of rooting containers made from peat. Rooting containers also can be made from plastic flats, metal flats, plastic foam cubes, or rock wool fibers.

Figure 4.5 - Peat Containers

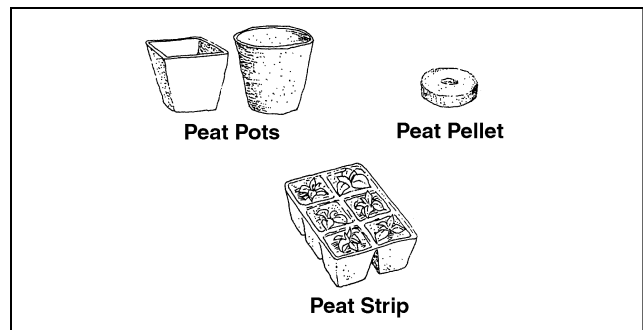
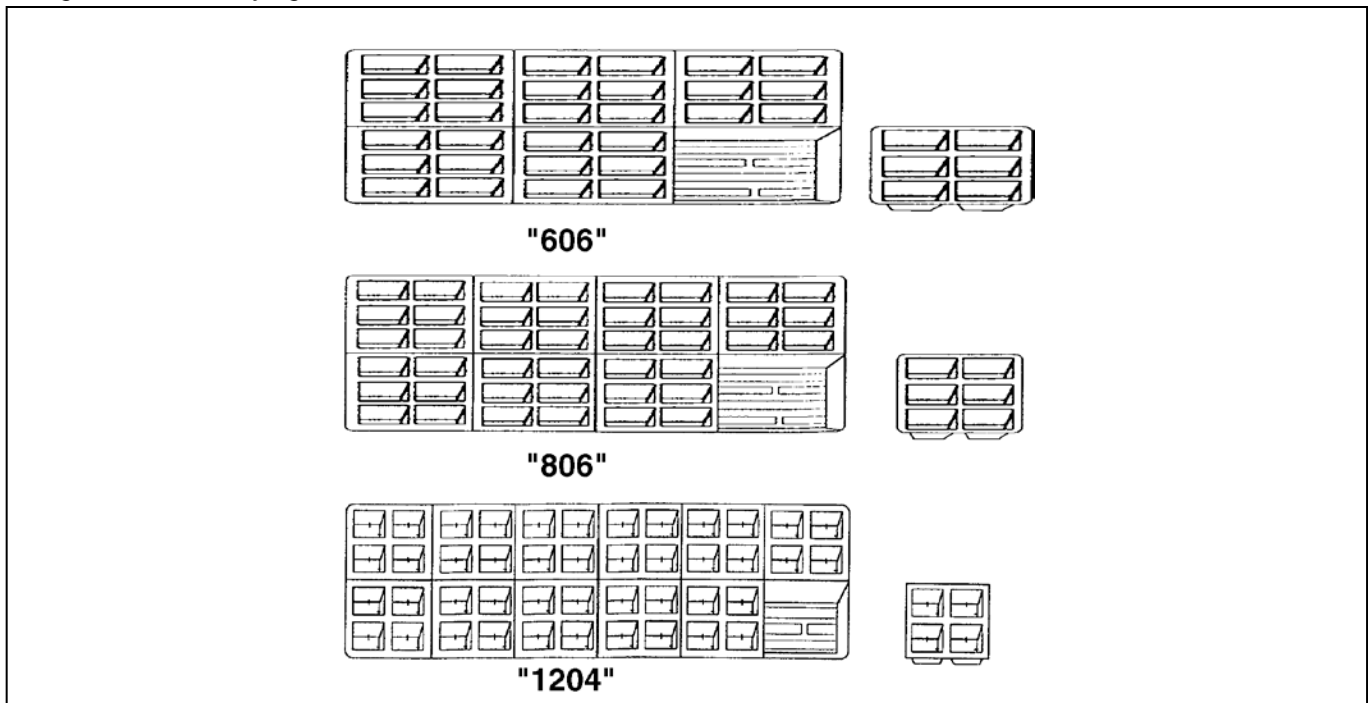

Figure 4.6 - Identifying Cell Packs



Greenhouse Operation and Management

Bedding plant containers, made of plastic, produce essential crops for the retail greenhouse owner. *Multicell packs*, typically containing 36, 48, or 72 cells per flat, are usually used to produce spring flowering annuals. See Figure 4.6 as shown above.

Plant packs usually contain one to six cells per unit and six to eight units per flat. Most bedding and garden vegetable plants are grown in these containers. *Individual pots*, usually made of plastic, come in assorted sizes; 2-4 inches is the most common. These pots are used to produce larger bedding plants.

Foliage and flowering plant containers range from 2 to 12 inches or larger. The width and depth of *standard pots* are equal. This type of pot is best for plants that are not top heavy. The height of an *azalea pot* is 3/4 of its width, making it ideal for shorter plants with spreading foliage. Its wide base provides stability for top-heavy plants. The height of a *rose pot* is 1 1/2 times its width. It is ideal for plants with large, deep root systems. In a *bulb pan*, the width is twice the depth and is best for shallow-rooted plants. *Hanging baskets* are suitable for many types of plants, especially those whose foliage drapes over the container, such as English ivy. Figure 4.7 illustrates these pots.

Figure 4.7 - Container Shapes

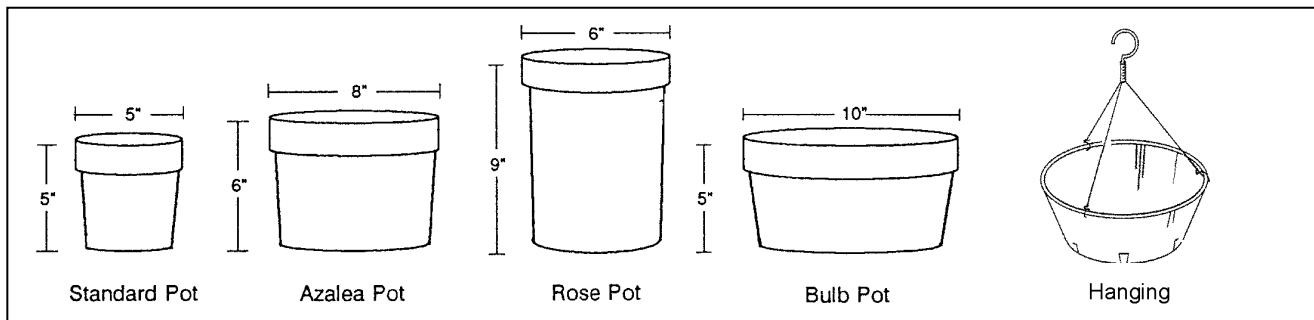

Common Materials for Growing Containers

Plastic is the most common material used for plant containers. Round plastic pots, grouped

together, effectively circulate air. Square containers maximize space efficiently; the greenhouse owner can group them close together on benches. However, less air circulates among square pots, which can lead to diseased leaves.

Plastic containers offer several advantages. They are lightweight, making lifting and shipping easy, and inexpensive. New plastic pots are sterile and can be used immediately; used containers must be sterilized with liquid chemicals. Plants grown in plastic containers are less likely to have fertilizer residue or algae buildup and require less watering. Finally, these containers come in a wide selection of sizes, shapes, and colors.

But there are some disadvantages to using plastic. The first problem is that they are not porous, which means that the material does not “breathe.” As a result, the root system has less aeration and the growing medium can become waterlogged. Another drawback is that plastic containers can crack and become brittle with age. Also, using plastic pots presents an environmental concern of how to dispose of them in a responsible manner.

For centuries, clay has been used as a plant container. It is porous; aeration and gas exchange between the plant and the environment optimize growth. Clay pots drain very well, which prevents

the growing medium from becoming waterlogged. They are also sturdy, less likely to tip, durable, and can be steam sterilized and reused. The disadvantages are that plants dry out faster and require watering more frequently. Fertilizer residue and algae accumulate in clay pots. In

Greenhouse Operation and Management

addition, they are heavy to lift and ship, and they break easily. Clay pots also tend to be relatively more expensive than plastic or peat pots.

Peat pots are made from peat moss that is pressed into sheets and formed into shapes. Seedling roots grown in peat pots penetrate directly through the container into the soil. The entire peat container can be transplanted into the soil, thereby reducing stress and lessening damage to the roots. Unfortunately, peat pots do not last very long and they can dry out quickly and become difficult to rewet.

Summary

Having high-quality growing media is essential to successful crop development. Soilless mixes are preferred, but field soil may be used if it is pasteurized to achieve desirable characteristics. Water-holding capacity, aeration, and drainage are key factors that determine whether plants thrive. A medium's pH and cation exchange capacity are additional considerations. Organic matter, minerals, and other materials contribute amendments that offer unique assets. Various types of plant containers in different materials accommodate specific needs for greenhouse-grown plants.

Credits

Acquaah, George. *Horticulture: Principles and Practices*. Upper Saddle River, NJ: Prentice Hall, 1999.

“Air, Water and Media...Putting Them All Together.” <<http://aggie-horticulture.tamu.edu/greenhouse/guides/green/air.html>> accessed 12/17/01.

Boodley, James W. *The Commercial Greenhouse*, 2nd ed. Albany, NY: Delmar Publishers, 1996.

Cooper, Elmer L. *Agriscience: Fundamentals & Applications*, 2nd ed. Albany, NY: Delmar Publishers, 1995.

Greenhouse Operation and Management (Student Reference). University of Missouri-Columbia: Instructional Materials Laboratory, 1990.

“Growing Media.” <<http://aggie-horticulture.tamu.edu/greenhouse/guides/green/media.html>> accessed 12/17/01.

“Growing Media & pH.” <<http://aggie-horticulture.tamu.edu/greenhouse/guides/green/ph.html>> accessed 12/17/01.

Herren, Ray V. and Roy L. Donahue. *The Agriculture Dictionary*. Albany, NY: Delmar Publishers, Inc., 1991.

“Horticultural Coir Ltd.” <<http://www.coirtrade.com/coir.html>> accessed 2/12/02.

Lee, Jasper S., Series Editor. *Introduction to Horticulture: Science and Technology*, 2nd ed. Danville, IL: Interstate Publishers, Inc., 1997.

Nelson, Paul V. *Greenhouse Operation and Management*, 3rd ed. Reston, VA: Reston Publishing Company, Inc., 1985.

Pasian, Claudio C. “Ohio State University Extension Fact Sheet - Physical Characteristics of Growing Mixes.” <<http://ohioline.osu.edu/hyg-fact/1000/1251.html>> accessed 12/19/01.

Unit IV: Plant Growth

Lesson 3: Irrigation

Plants cannot survive without water. Of all the cultural practices that the greenhouse owner performs, irrigation contributes most directly to the growth and healthy development of plants. Lesson 3 addresses general factors affecting irrigation in the greenhouse, explains how often to water crops, provides guidelines for watering plants correctly, and describes several irrigation methods.

Irrigating Greenhouse Crops

Proper irrigation practices and quality water are critical to crop success.

Water's major role in plant growth is to dissolve and translocate nutrients throughout the plant, as detailed in Plant Processes (Unit III, Lesson 2). Plant cells help support the structure of the plant when they are filled with water.

The *growing medium* (see Unit IV, Lesson 2) can create moisture stress in plants under certain circumstances. If the medium's capacity for absorption, retention, and drainage is inadequate, the plant suffers. As the medium's pores (capillaries) absorb and attempt to retain water, the force of gravity tries to drain water from the container. This conflicting interaction is resolved by the porosity and depth of the medium. A growing medium with large particles is porous; this facilitates drainage after irrigation. The depth of the medium relates to the height of the planting container. Water in tall containers is easily pulled through the medium; drainage is complete. In shorter containers, the medium's capillaries resist the force of gravity; therefore, water is retained in the container.

Figure 4.8 demonstrates how the relationship between the medium's porosity and depth influences absorption, retention, and drainage.

Figure 4.8 - Interaction Between Growing Medium's Porosity and Depth

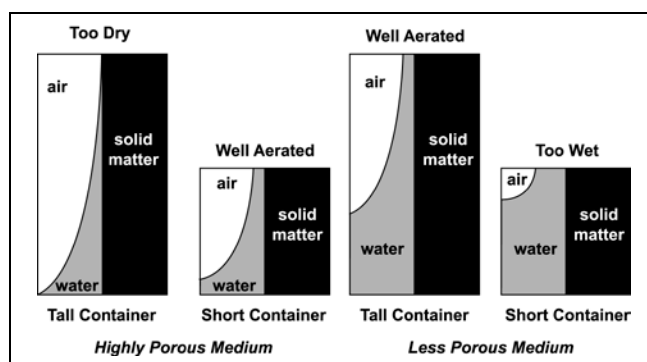

Air temperature is another factor in moisture stress. During the hottest part of the day, air in the greenhouse may reach 120°F (49°C) or higher. At this point, the rate of transpiration accelerates and the relative humidity decreases substantially, depleting water from plant cells. Excessive air movement also increases transpiration because it prevents water vapor from accumulating on the leaves. Monitoring and regulating air temperature control the effects of transpiration in greenhouse-grown plants.

Basic concerns about irrigation include providing uniform watering, minimizing the amount of water/fertilizer runoff, minimizing the amount of water on foliage, and considering the integration of a fertilizer injection system directly into the irrigation system.

Water contains chemicals that can harm plants. For example, fluorine is often added to public water systems to prevent tooth decay. The amount

Greenhouse Operation and Management

added is 1 part per million (ppm). Yet, fluoride (the compound made from fluorine) in a concentration of just 5 parts per *billion* reduces leaf size by 25-35%. A concentration of 0.25 ppm fluoride causes necrosis in leaf tips. Softened water contains high levels of sodium that destroy soil structure, causing poor drainage. An accumulation of only 1 ppm sodium in some plants (e.g., carnations) causes the petals to stick together so they cannot open up properly.

Frequency of Crop Irrigation

Determining how often to irrigate greenhouse-grown crops depends on various factors: water-holding capacity of the growing medium, container type, internal environment of the greenhouse (humidity, temperature, and light), season of the year, and the plant itself (species, size, and stage of growth). The soil depth of the plant's roots is also a consideration.

A critical factor is knowing when to irrigate plants. The greenhouse owner can visually discern when the plant starts to wilt, dries up, or fades. If the weight of the container is unusually light, it indicates that the plant needs water. Placing a dry stick in the medium for a period of time and periodically removing it also reveal when to water the plant. If the stick stays dry, water the plant. If the growing medium clings to the stick, do not water.

Knowing the amount and frequency of irrigation for greenhouse crops prevents two detrimental consequences: underwatering and overwatering. *Underwatering* creates moisture stress if the plant is deprived of water. Then the cells shrink and the plant wilts. At this point, the stomata (pores in the leaf surface) close up to prevent any further loss of moisture. But they also restrict carbon dioxide from entering into the leaf, hindering photosynthesis and stunting plant growth. When roots have no access to water and dissolved minerals, they cannot transmit needed moisture to the leaves, stem, and emerging flower. The plant

then develops shorter internodes, smaller leaves, and harder and tougher plant tissue.

Overwatering is also harmful, especially for seedlings. If overly saturated, the root system is unable to exchange gases; consequently, the amount of available oxygen is severely limited. As a result, the root tissue is damaged and the risk of disease increases significantly. Plants wilt and develop spindly, leggy stems; overall growth slows.

Basic Guidelines for Irrigation

Successful irrigation results from adhering to a few fundamental guidelines. Use the appropriate growing medium for each crop to ensure adequate absorption, water retention, and drainage. Because plants differ in how much water they require, the greenhouse owner should regulate the amount and frequency of irrigation accordingly.

Watering plants thoroughly leaches (flushes) soluble salts and excess nutrients that can harm the root system if they accumulate in the growing medium.

The proper method for watering is to irrigate the entire area around the roots, ensuring that the root system never dries out completely. Control the flow of water to prevent water from spilling over the top of the container. Irrigate plants until water drains from the bottom of the pot. The best time to irrigate is early in the day to replenish the water that evaporated from leaves and flowers. To prevent disease, do not directly moisten the foliage and flowers because this induces decay. Also, prevent pathogenic contamination by keeping the end of hoses off of the floor.

Delivering Water to Plants

As mentioned briefly in Unit II, Lesson 2, the two basic irrigation systems are manual and automated. This lesson expands upon various

irrigation techniques and explains how the equipment is used in each method.

The manual method uses handheld hoses and wands. This method is widely used in small greenhouse operations. However, it is labor intensive, costly, and difficult to water plants uniformly.

There are three basic automatic systems: overhead, surface, and subsurface. *Overhead delivery systems* use sprinklers to spray water over bedding plants and expose the foliage directly to water. This method is still used in some established greenhouses. However, the sprinklers have several disadvantages. If the irrigation system contains nutrients, the sprinklers deposit salt residues on the leaves. When overhead systems irrigate plants, the water might gather in puddles and oversaturate the growing medium. In addition, evaporation results from using overhead sprinkler systems. There is an increased risk of disease when the foliage is wet.

A better option is the *boom irrigation system* that waters bedding plants, potted plants, and seedlings. A water wand hangs above plants and travels across the greenhouse, spraying water onto plants. Spray stake/nozzle systems are mounted near plants and spray plants from above and from the sides. This custom-built system accommodates the greenhouse's specific dimensions, uses space efficiently, and delivers fertilizer during irrigation ("fertigation"). Compared to manual irrigation techniques (e.g., hoses), boom systems save 40% in water.

Surface delivery systems, used to irrigate cut flowers and row crops, apply water to the entire soil surface under the foliage. A uniform, optimal amount of water is applied to the base of the plant. As a result, the leaves do not get wet, reducing the rate of evaporation from the foliage and soil. The growing medium does not become waterlogged and nutrients do not leach into the soil. Drip emitters have small tubes with weights attached

that are placed in individual pots. They slowly dispense drops of water directly to the medium. Drip irrigation also prevents exposing roots to pathogens that are spread by moving water. The drip irrigation system uses less water, making it an economical option, and this system has been shown to increase yields. Soaker hoses, oozing water from tiny holes, are put at the bottom of the plant. Closely planted flowerbeds are effectively irrigated with bubblers, which are similar to drip emitters but deliver a higher rate of water.

In *subsurface (subirrigation) delivery systems*, water is applied directly to the growing medium without wetting the foliage. Water is applied under the pots. The two basic methods are the capillary mat system and ebb and flood system. In the **capillary mat system**, plant containers are placed on top of a soaked, synthetic mat that rests on a level bench in the greenhouse. The bench is protected with a sheet of plastic. Dripping water runs off the bench and thereby prevents soluble salts from accumulating on the mat. The best pots to use are plastic; clay loses moisture through the sidewalls.

First, a drip tube uniformly waters the mat. The greenhouse owner places the plants on the mat and waters them from above using a hose. This creates a column of water that extends from the growing medium to the mat. Through capillary action, water is drawn upward from the saturated mat through the drainage hole into the growing medium of each plant.

The size of the medium's pore spaces affects how high the water rises. In finely textured soil with tiny capillaries, water rises to the highest level. Capillary action occurs because the water rises to a given height in "tubes" (capillaries), which have very narrow diameters. The pore spaces in the growing medium function as capillary tubes and carry the water from the mat to the roots. Figure 4.9 illustrates how pore size affects capillary action. Water rises to the highest level in the smallest capillary tube (A) and to the lowest level in the largest capillary tube (C).

Greenhouse Operation and Management

Figure 4.9 - Capillary Action of Water in Growing Medium

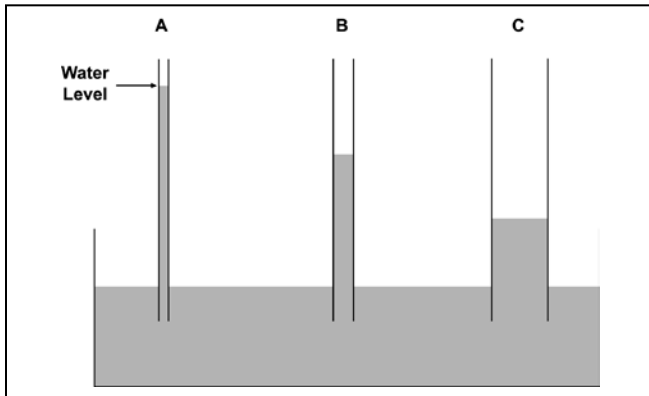

However, capillary action also affects the quality of the growing medium. Through water evaporation, soluble salts are lifted from the bottom of the pot and deposited in undesired concentrations on top of the growing medium. To get rid of these harmful chemicals, the greenhouse owner should periodically water the plants from above. This leaches the excess salts from the top of the container and balances their distribution throughout the medium.

In the **ebb and flood system**, flats of plants rest on specially constructed, raised, waterproof benches. Each bench must be absolutely level and have a trench for the nutrient solution and several pipes to carry a certain number of gallons of water per minute. The amount of water depends on the size of the greenhouse operation. The irrigation solution (water and nutrients) is pumped from a central storage tank into the bench and spreads quickly and evenly over the growing medium. It remains on the bench for a few minutes and then drains back into the storage tank for recycling. The advantages of the ebb and flood system are that it never wets the foliage, which promotes disease, and that it can be applied any time day or night. A computer can regulate the entire operation. Ebb and flood is a completely closed recirculating system that does not contaminate the groundwater. The Environmental Protection Agency (EPA) requires the prevention of groundwater contamination from runoff due to

irrigation. The ebb and flood system uses concrete floors so this mandate can be satisfied

Summary

The key to developing a healthy crop is having a well-run irrigation system that meets the specific needs of each plant. Knowing how and when to water, avoiding moisture stress and overwatering, and determining the best irrigation method help the greenhouse owner maximize yield and profit.

Credits

Acquaah, George. *Horticulture: Principles and Practices*. Upper Saddle River, NJ: Prentice Hall, 1999.

Alama, M. and I. Broner. "Subsurface Microirrigation - Crops." Colorado State University Extension no. 4.716. <<http://www.ext.colostate.edu/pubs/crops/04716.html>> accessed 2/13/02.

Boodley, James W. *The Commercial Greenhouse*, 2nd ed. Albany, NY: Delmar Publishers, 1996.

Broner, I. "Irrigation Schedule: Crops." Colorado State University Extension no. 4.708. <<http://www.ext.colostate.edu/pubs/crops/04798.html>> accessed 2/13/02.

Broner, I. "Irrigation Scheduling: The Water Balance Approach." Colorado State University Extension no. 4.707. <<http://www.ext.colostate.edu/pubs/crops/04707.html>> accessed 2/13/02.

Cooper, Elmer L. *Agriscience: Fundamentals & Applications*, 2nd ed. Albany, NY: Delmar Publishers, 1995.

"DIG Irrigation Products - Drip and Microsprinklers for Home & Garden." <<http://www.digcorp.com/diy/introduc.htm>> accessed 2/14/02.

Greenhouse Operation and Management (Student Reference). University of Missouri-Columbia: Instructional Materials Laboratory, 1990.

Herren, Ray V. and Roy L. Donahue. *The Agriculture Dictionary*. Albany, NY: Delmar Publishers, Inc., 1991.

Lee, Jasper S., Series Editor. *Introduction to Horticulture: Science and Technology*, 2nd ed. Danville, IL: Interstate Publishers, Inc., 1997.

Nelson, Paul V. *Greenhouse Operation and Management*, 3rd ed. Reston, VA: Reston Publishing Company, Inc., 1985.

“Water Efficiency Practices for Agricultural Irrigation.” Environmental Fact Sheet - WD-WSEB-26-5, New Hampshire Department of Environmental Services, Concord, NH.
<<http://www.des.state.nh.us/factsheets/ws/ws-26-htm>> accessed 2/12/02.

Unit IV - Plant Growth

Lesson 4 - Nutrients

Without nutrients, plants would not grow. This lesson identifies the impact of macro- and micronutrients, oxygen, hydrogen, and carbon and addresses the consequences if a deficiency occurs. Factors that affect availability of nutrients into the plant are also outlined.

There is a distinction between “plant nutrition” and “plant fertilization.” Plant nutrition indicates specific chemical elements that are available (absorbed) in the plant. Plant fertilization is a procedure of adding more nutrients to supplement the growing medium.

Effect of Nutrients on Plant Growth

All plant growth and development depend upon proper nutrition. Each type of plant needs adequate levels of minerals to grow at optimum rate. Insufficient and excessive amounts of nutrients adversely affect plant growth. Greenhouse plants need more nutrients than other agricultural crops. They also require applications of fertilizers as nutritional supplements to promote plant growth. (Fertilizers are discussed in the next lesson.)

Essential Nutrients for Plant Growth

The minerals that soil needs are divided into two groups: macronutrients (major nutrients) and micronutrient (minor, or trace elements). These minerals are actually forms of soluble salt. Table 4.3 lists these nutrients.

Table 4.3 - Essential Soil Macronutrients and Micronutrients

Macronutrients	Micronutrients
<i>Primary</i>	Iron (Fe)
Nitrogen (N)	Manganese (Mn)
Phosphorous (P)	Boron (B))
Potassium (K)	Copper (Cu)
<i>Secondary</i>	Zinc (Zn)
Sulfur (S)	Molybdenum (Mo)
Calcium (Ca)	Chlorine (Cl)
Magnesium (Mg)	Nickel (Ni)
	Sodium (Na)

A primary macronutrient, *nitrogen*, which is found in chlorophyll and enzymes, is essential to growth. It helps the plant resist disease and sustain environmental extremes, such as drought and freezing. Nitrogen is recycled within the plant. Plants absorb nitrogen as nitrate ions - its inorganic form. By becoming part of the plant's

Unit IV: Plant Growth

Lesson 5: Fertilizer

Fertilizer nurtures healthy plant growth. Because each plant requires different macro- and micronutrients, the amount and formulation of fertilizer vary accordingly. This lesson highlights features of a fertilizer management plan, identifies sources and forms of fertilizer, details aspects of a fertilizer analysis, and describes techniques for applying fertilizer.

Fertilizer Management Plan

The purpose of a fertilizer management plan is to prevent and correct nutritional deficiencies. A well-managed program makes plants more resistant to disease and improves their appearance. It also ensures efficient, maximum growth, which increases the greenhouse operation's profits. To ensure abundant, healthy crops, this program should quantify the amount and frequency of fertilizer given and match specific types of fertilizer to the unique nutritional needs of each plant. Fertilizer requirements vary per species and development at key stages: seedling/cutting, vegetative (foliage growth), and flowering.

Fertilizer Sources

Plant fertilizer is derived from organic and inorganic sources. Organic fertilizer, from once-living matter, is made from natural components (e.g., animal manure, decayed plants, and decomposed microorganisms) and processed elements (e.g., bone meal, fish emulsion, and sewage sludge). When these materials decay, only small amounts of nutrients are released into the medium. The precise amount is unknown, making uniform application difficult. To make certain that the soil receives enough nutrients, large quantities are required. For example, to equal the fertility provided from 100 pounds of inorganic fertilizer, 1 ton of cow manure must be added. This is

costly, necessitates ample storage facilities, and requires personnel capable of managing this large quantity. Also, as organic residues break down, the rate of decomposition is extremely slow and variable. A gradual, irregular breakdown of organic sources does not foster healthy development. Plants require a steady supply of nourishment.

Inorganic fertilizer comes from synthesized mineral salts. Its concentration is greater than that of organic fertilizer. Therefore, overfertilization must be avoided to prevent injuring the roots and burning leaf tissue. Inorganic fertilizer releases nutrients rapidly and is readily available to the plant. It disseminates evenly throughout the growing medium

Available Forms of Fertilizer

Fertilizer is available in several forms. Slow-release formulations offer significant advantages. Because greenhouse-grown crops are frequently watered, nutrients are leached from the growing medium. But thanks to industrial processes that coat particles of slow-release fertilizers, the rate of releasing nutrients into the medium is prolonged. Plants thus receive a steady food supply. In addition, this form of fertilizer is less likely to burn the plant. A commonly used slow-release fertilizer is Osmocote, in which fertilizer particles are covered with a plastic coating. The thickness of this coating depends upon the fertilizer analysis (discussed below). The plant's roots gradually absorb a small amount of the Osmocote fertilizer solution.

Granular forms can be mixed into or applied on top of the growing medium; some are dissolved in water before application. They are available as

Greenhouse Operation and Management

stakes or tablets and placed directly into the medium.

Liquid or dry forms of fertilizer can be injected into the irrigation system (fertigation); the amount used is measured in parts per million (ppm).

Fertilizer Analysis

The proportion of nutrients in the fertilizer formulation (called fertilizer analysis) is the percent by weight of each element, as analyzed by chemical laboratories. This helps the greenhouse owner select the appropriate fertilizer formulation for specific plants. The quantity of fertilizer used is based on this chemical analysis. A “complete” fertilizer contains three macronutrients: nitrogen (N), phosphorous (P), and potassium (K). The fertilizer label lists the percent of each of these elements in the following sequence: N-P-K. For example, a bag of fertilizer labeled 20-17-16 denotes 20% nitrogen, 17% P₂O₅, and 16% K₂O₅. Other nutrients may be included.

Calculating the Amount of Fertilizer

In their original formulations, dry and liquid fertilizers are concentrated and must be mixed with water at a specified ratio. It is important to check the dilution ratio of each fertilizer and then calculate the amount needed for the mixture. The fertigation equipment has to be calibrated so it delivers the proper dilution ratio.

Concentration rates are calibrated in parts per million, as calculated by the following formula:

$$\frac{\text{desired ppm}}{\text{percent of active ingredient} \times 75} = \frac{\# \text{ oz}}{100 \text{ gallons water}}$$

- Multiply the percent of active ingredient in the fertilizer by 75 (a constant).
- Divide this number by the ppm needed. This number represents the number of ounces of

fertilizer per 100 gallons of water necessary to produce the proper concentration.

To mix smaller amounts of fertilizer, use a proportion. First determine the correct number of ounces per 100 gallons, as indicated above. Then use the following formula:

$$\frac{\# \text{ oz}}{100 \text{ gallons of water}} = \frac{?}{\text{calibration ratio}}$$

- To find the unknown number of ounces (?), divide by the total calibration ratio. For example if the calibration ratio is 1:13, the denominator is 14.
- Cross-multiply to solve for ? (the unknown number of ounces). The result represents the number of ounces of fertilizer to add to 1 gallon of water in order to create a solution with the correct ppm.

Applying Fertilizer

When applying fertilizer, it is essential to follow directions for a given formulation carefully, especially concerning the amount and frequency of fertilization. Insufficient fertilizer applied infrequently creates nutritional deficiencies. Excessive fertilizer applied too often is detrimental to the plant. As a general rule, the growing medium must be moist before applying fertilizer. If fertilizer is applied to a dry medium, it injures the roots.

When dry granular or liquid fertilizers are dissolved in water and applied to plants, the nutrients rapidly leach from the growing medium and are immediately absorbed by the plant’s roots. Because they act so quickly, these formulations may require reapplications. But caution is required; the greenhouse owner must not apply too much of these fertilizers.

Applying low concentrations of fertilizer with each watering is a common technique. When

watering, provide a balanced fertilizer to meet the needs of each plant. If the irrigation promotes sufficient drainage, no fertilizer salts will accumulate, which could harm the growing medium. A constant feed system that supplies nutrients at every watering or every other watering is generally the best irrigation method.

Another method of applying fertilizer is to use a hose-siphoning device. A siphon is positioned between the water outlet and hose. A narrow tube extending from the siphon is placed in the fertilizer solution. Through the force of suction, fertilizer is drawn from the solution into the tube and the stream of water. See Figure 4.12. This method is easy and inexpensive. The calibration ratio usually ranges from 1:12 to 1:16.

Figure 4.12 - Hose-Siphoning Device Used to Apply Fertilizer

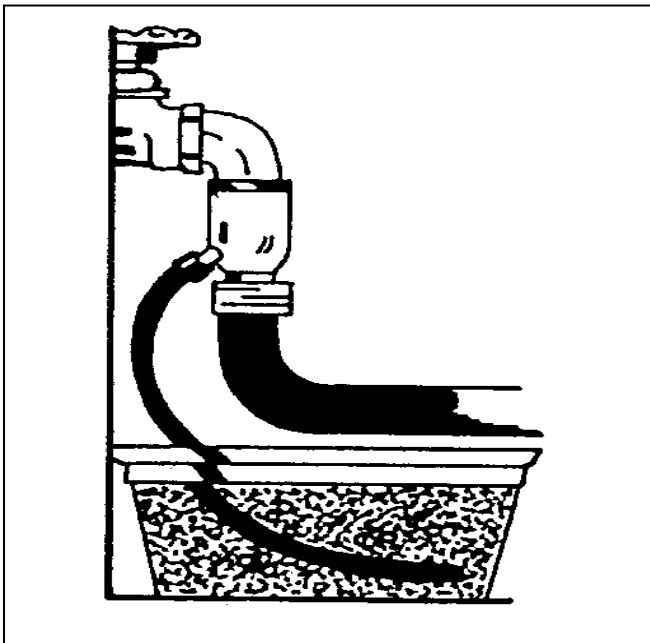

Another type of device is the dosmatic injector, as illustrated in Figure 4.13.

Figure 4.13 - Dosmatic Injector

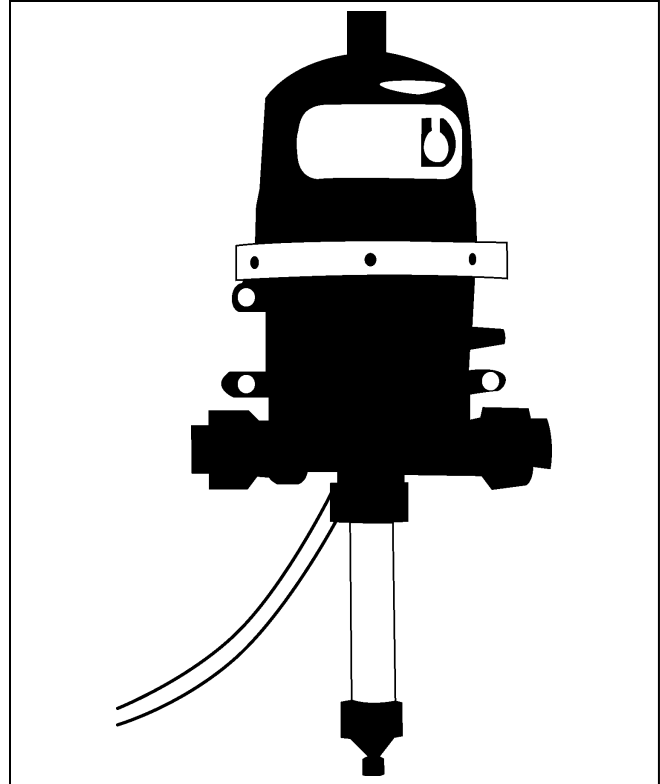

Summary

Maintaining an effective fertilizer management plan helps the greenhouse owner cultivate healthy, productive crops. Different formulations are available to accommodate nutritional needs of each plant. Calculating the correct ratio of concentrated fertilizer to water is critical. When applying fertilizer it is important to follow directions on the label. Over- or underfertilization harms the plant. Several methods for applying fertilizer are available.

Credits

Boodley, James W. *The Commercial Greenhouse*, 2nd ed. Albany, NY: Delmar Publishers, 1996.

Cooper, Elmer L. *Agriscience: Fundamentals & Applications*, 2nd ed., Albany, NY: Delmar Publishers, 1995.

Greenhouse Operation and Management

Greenhouse Operation and Management (Student Reference). University of Missouri-Columbia: Instructional Materials Laboratory, 1990.

Lee, Jasper S., Series Editor. *Introduction to Horticulture: Science and Technology*, 2nd ed. Danville, IL: Interstate Publishers, Inc., 1997.

Nelson, Paul V. *Greenhouse Operation and Management*, 3rd ed. Reston, VA: Reston Publishing Company, Inc., 1985.

Unit V: Plant Propagation

Lesson 1: Sexual Propagation

The two lessons in this unit investigate sexual and asexual methods for propagating plants. Lesson 1 examines sexual propagation: legal issues, its environmental conditions, dormancy period, and stages of germination. In addition, this lesson discusses procedures for planting seeds, distinguishes between the germination of monocots and dicots, and describes when and how to transplant seedlings. Caring for seedlings after germination and transplanting is also described.

Sexual Propagation

Sexual propagation uses seeds to produce new plants. In order for germination to occur, environmental conditions must be ideal. These conditions are discussed below.

For sexual propagation to be successful, it is important to select high-quality seeds that are free of disease and insects, broken seeds, weeds, or other seeds. Hybrid seeds are expensive but they offer significant advantages: greater resistance to disease, generally more vigorous plants, and higher yields. To store seeds, keep them dry and cool. Put them in paper packets inside sealed, clean, dry glass jars.

Direct seeding means that the seeds are planted outdoors; no transplanting is involved. The seeds are placed in the same container that will be used for sales. Inside seeding is planting the seeds in the greenhouse and later transplanting the developed plant, either to a larger container or outside. The growing media should be clean, free of debris and disease, loose, and finely textured.

Environmental Conditions for Seed Germination

Four principal environmental conditions play key roles in germination. Adequate amounts of moisture allow the seeds to absorb water. After the seeds are sown, the best way to moisten the growing medium is to apply a fine spray and cover the medium to retain moisture.

Temperature requirements vary among warm weather and cool-weather crops. The general range is 68-86°F. It is important that the medium's temperature remains constant. If the medium is too cool, use supplemental heating.

Light requirements vary. For seeds that need light to germinate, sow them shallowly and do not cover them (e.g., lettuce). Most ornamental bedding plants (e.g., begonias and petunias) depend on light for germination. For some seeds, light may inhibit germination, so no light is required. Sow these seeds more deeply and place them in a dark area (e.g., geraniums).

Air (oxygen) is essential because germination is an aerobic process. Dormant seeds do not require much oxygen, but as the plant develops, the need for oxygen increases. A deficit of oxygen hinders respiration. The growing medium must have good porosity to ensure proper aeration.

Sexual propagation involves legal considerations. In an effort to encourage biotechnological development, the U.S. government passed the Plant Variety Protection Act. This law gives scientists or breeders of new varieties exclusive marketing rights to their seeds for 18 years. This law and subsequent amendments restrict the actions of the buyers of these more resilient seeds, namely, a grower cannot sell surplus seeds. For

Greenhouse Operation and Management

more information, contact the Commissioner, Plant Variety Protection Office, Agricultural Marketing Service, National Agricultural Library Bldg., Room 0, 10301, Baltimore Blvd., Beltsville, MD 20705-2351.

In addition to federal regulations, a greenhouse operator must follow state laws. In the state of Missouri, all who handle nursery stock, even if they give it away, must be inspected and certified. The inspector is looking for signs of insect and disease infestation. Fees for this service are based on the size of the greenhouse as measured in square feet under glass. For more information, contact State Entomologist, Missouri Department of Agriculture, P.O. Box 630, Jefferson City, MO 65102-0630 - Phone: (573) 751-5507; Fax: (573) 751-0005.

Dormancy

Dormancy is the resting stage for seeds that prevents them from germinating until specific environmental conditions are favorable for growth. For example, the dormancy period for annual seeds that bloom in the fall lasts until spring. Otherwise, if the seeds germinate too soon, the frost would kill the emerging plants. Seeds of many greenhouse-grown plants do not have a dormancy period and can be planted at any time. However, some plants, such as geraniums, have a hard, protective seed coat that prevents immediate germination. To offset the effects of dormancy, the seed coat undergoes scarification. This is a process in which the seeds are scraped or scratched to increase water absorption. A manual method for scarifying is to rub the seed coat with sandpaper or to nick a portion of it. A chemical approach is to soak the seeds in sulfuric acid to soften the seed coat.

Some seeds require a different technique: stratification. Seeds are planted in a moist growing medium at 32-50°F for several weeks. Conversely, to induce germination for other types

of plants, exposure to heat is required to weaken the seed coating so water absorption is possible.

Germination Process

As soon as seeds absorb water through the growing medium, the germination process begins. When the water penetrates into the seed, a growth hormone develops that eventually moves into cellular layers. This triggers the production of enzymes that stimulate various chemical reactions within the cells. New cells and tissues are produced. The radicle is the first to appear from the seed. Next is the plumule (coleoptile), the emerging plant's first shoot. With the appearance of leaves on the seedling, photosynthesis begins and the plant supplies its own food.

Steps for Planting Seeds

The first step for planting seeds is to fill the container 3/4 inch from the top with moistened germination mixture. Be sure the pot has drainage holes. Level off the medium and tap to settle. Make shallow holes or rows according to directions on the seed packet. Place seeds in the holes or rows. Label the pot or flat with the plant type, variety, and date of sowing. Cover seeds with a dry medium, generally twice as much as the seeds' diameter. Plastic, multicell packs are frequently used for planting seeds.

Provide seeds with a fine mist of water and keep them warm. Cover the container with clear plastic or glass in order to retain the moisture. Observe daily for signs of too much or too little moisture and for excess heat. Watch for germination.

Differences in Germinating Monocots and Dicots

Monocots undergo hypogeous germination (cotyledon remains underground). First the seed swells as moisture is absorbed. Finally, the seed coat ruptures. The radicle grows down and the first internode and epicotyl grow up. After the

epicotyl emerges, new leaves form and food production starts. The new root system grows just beneath the medium above the first internode. Figure 5.1 illustrates this process.

Figure 5.1 - Steps in Seed Germination of a Monocot

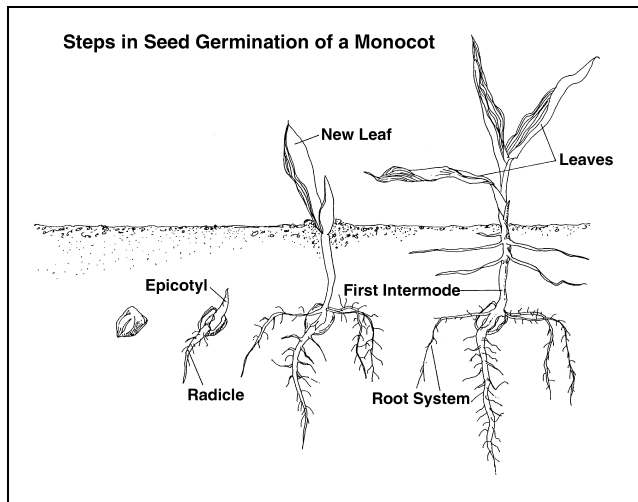

Dicots undergo epigeous germination (cotyledon emerges aboveground). As with monocots, the seed swells as moisture is absorbed. The seed coat splits and the radicle emerges and grows down. The hypocotyl elongates, forms an arch, and pulls the cotyledon upward. When the hypocotyl reaches light, elongation ceases and the hypocotyl straightens up and pulls the cotyledon out of the medium. The cotyledon opens, turns green, and provides food until the true leaves develop. The first true leaves unfold from the epicotyl, exposing the growth bud. The cotyledon dies, dries up, and falls off. See Figure 5.2.

Figure 5.2 - Steps in Seed Germination of a Dicot

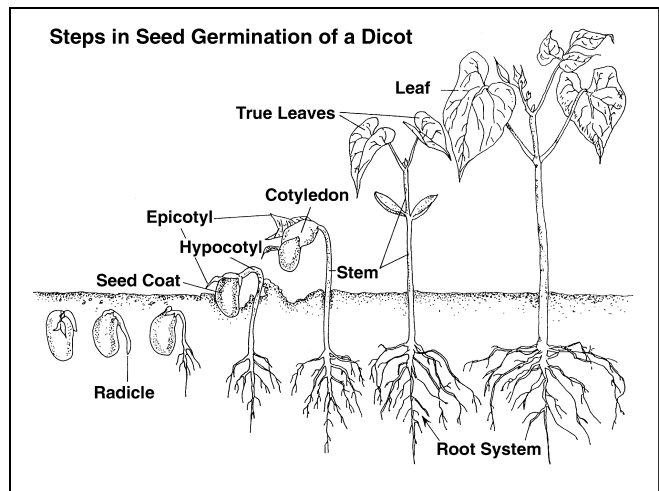

Caring for Seedlings After Germination

Once the seedlings begin to emerge, remove the plastic or glass covering. Move the plant to a brightly lit area. The growing temperature should be 10°F cooler than the temperature for the germination period. Monitor the amount of water the plant receives and keep the growing medium moist but not soggy. Be sure to allow the medium to dry completely between waterings and ensure that seedlings do not wilt at any time.

Promptly fertilize plants that were grown in soilless media. Apply a water-soluble fertilizer in a 20-20-20 formulation (1/4 of the recommended strength) a few days after germination. Twice a week thereafter, apply the appropriate amount of nitrogen for each crop in a diluted solution. Always observe the plant's reaction to the fertilizer; too much is harmful.

The emerging plant needs protection from diseases. The best preventative steps are to use a soilless mix or pasteurized field soil and to sterilize containers. Always provide ample air circulation and permit the medium to dry out between waterings.

Despite precautions, diseases may develop and endanger the growing plants. Fungi cause damping-off, a disease that rots stems at the base

Greenhouse Operation and Management

of the medium. If the infection is limited, the best approach is to get rid of the plants and medium. If the infection is widespread, drench the entire area with a fungicide.

Transplanting Seedlings

The best time to transplant seedlings is after the first set of true leaves develops. If transplanting is delayed, the seedlings become overcrowded and spindly and the plant's health suffers. Because transplanting traumatizes the seedling, the plant must be prepared. This is accomplished through hardening-off. The seedling is put in a cooler environment and watered less frequently for a period of time. The length of the hardening-off period varies with each plant.

After the hardening-off period, the seedling is watered and carefully lifted out of its present container with a small trowel, fork, or knife. Some of the medium should be kept around the roots, and the roots must never dry out. After the container is filled with a moist growing medium, dig a hole in the middle to receive the seedling. This hole should be slightly larger than in the other pot. The extra depth in the new pot gives the seedling room to grow. Add growing medium and gently pat around the base of the seedling. Give the transplanted seedling a final watering to prevent wilting.

Throughout the transplanting process, it is extremely important to be gentle when handling seedlings because they are fragile. As the plant is inserted into the growing medium, carefully hold the seedling by its leaves, not stem.

Caring for Seedlings After Transplanting

After seedlings are transplanted, they need special care. Direct light and intense heat are harmful, so it is important to keep seedlings in the shade or under fluorescent lighting for a few days and also to keep them away from heat.

Summary

Sexual propagation is the development of new plants from seeds. These seeds must be nurtured under specific environmental conditions. The dormancy period that several seeds undergo can be overcome by manual or chemical methods in order to enhance water absorption in the seed coat. Monocots and dicots undergo different stages during germination. Carefully nurturing seedlings after germination, during transplanting, and after transplanting ensures healthy crops.

Credits

Boodley, James W. *The Commercial Greenhouse*, 2nd ed. Albany, NY: Delmar Publishers, 1996.

Cooper, Elmer. *Agriscience: Fundamentals & Applications*, 2nd ed. Albany, NY: Delmar Publishers, 1995.

"General Information About 35 U.S.C. 161 Plant Patents." United States Patent and Trademark Office.
<<http://www.uspto.gov/web/offices/pac/plant/index.html>> accessed 5/3/02.

Greenhouse Operation and Management (Student Reference). University of Missouri-Columbia: Instructional Materials Laboratory, 1990.

Herren, Ray V. and Roy L. Donahue. *Delmar's Agriscience Dictionary*. Albany, NY: Delmar Publishers, 1999.

Lee, Jasper S., Series Editor. *Introduction to Horticulture*, 3rd ed. Danville, IL: Interstate Publishers, Inc., 2000.

"United States of America Plant Patent Amendments Act of 1998."
<http://www.upov.int/eng/nprlaws/usa/USA-Law-1998.pdf>> accessed 5/3/02

Unit V: Plant Propagation

Lesson 2: Asexual Propagation

The greenhouse owner can increase the amount of plants available for sale by using different methods of asexual propagation. This lesson compares the principles and techniques of budding, cutting, division, grafting, layering, and tissue cultures.

Asexual Propagation

In asexual (vegetative) propagation, a new plant is created from the buds, leaves, stems, or roots of a parent plant. It is a popular means of reproduction because it is a faster process than sexual (seed) propagation and it produces identical characteristics of the original plant. Frequently, plants grown from seeds cannot produce viable seeds. Asexual propagation is a less expensive method than sexual propagation. The reason asexual propagation works is that each plant cell contains all the genetic information needed to divide and reproduce itself.

General Considerations for Asexual Propagation

To ensure successful propagation, the greenhouse owner needs adequate supplies and equipment, a suitable growing environment, and an effective tracking system. Tools include sharp knives to cut parts from plants, divide plants, and make wounds in plant materials. Dibbles (sticks) are used to dig holes in the growing medium; puffer dusters and spray bottles are used to apply the rooting compound. Keeping propagation benches above the floor helps prevent exposure to pathogens.

Within the greenhouse environment, sanitation is mandatory. All tools and knives must be sterile and disinfected before use and after each cutting. Cuttings should be put in a sterile container until they are ready for planting. After each use, it is

important to sterilize rooting solutions. To ensure further cleanliness, discard any excess plant debris. To help plants flourish, use a soilless growing medium composed of vermiculite and perlite. This pathogen-free medium promotes drainage and aeration while retaining sufficient amounts of nutrients and water. Lighting for the cuttings is an important factor. During winter, for example, more light is required than during the heat of the summer. When too much light floods the greenhouse, the cuttings need shade. Cuttings also need balanced temperature (see below). The bottom temperature is generated from heating pipes or electric cables and is placed below the propagation benches. It generally should be 5-10°F higher than air temperature.

In order to keep track of the increase in plants, the greenhouse owner should maintain careful records. By labeling each plant accurately, the greenhouse owner can identify the plant's name and variety, date of propagation, and any special treatment received.

Asexually reproduced plants, except tubers, are federally protected. The Plant Patent Law of 1930 is similar to the Plant Variety Protection Act, passed in 1970, which regulates sexually propagated plants and tubers. A plant patent gives breeders the right to sell their plants and it controls who may propagate and sell subsequent plants and plant parts. This is referred to as a licensing agreement. A plant patent lasts 20 years. In 1998, the Plant Patent Act was amended. The revised Act explicitly protects the owner of a plant patent against unauthorized sale of plant parts that could be used to propagate the plant. It also expands protections on par with those for sexually propagated plants as covered by the Plant Variety Protection Act. For further information,

Greenhouse Operation and Management

contact the Assistant Commissioner for Patents, Washington, DC 20231.

In the state of Missouri, those who sell, transport, or give away nursery stock (perennials, woody stem plants, perennials, bulbs, roots, crowns, corms, rhizomes, and tubers) must be licensed. Twice a year, a state entomologist examines the nursery stock for infestations from pests and diseases. Fees for this service are based on the size of the greenhouse as measured in square feet under glass. For further information, contact the State Entomologist, Missouri Department of Agriculture, P.O. Box 630, Jefferson City, MO 65102-0630 - Phone: (573) 751-5507; Fax: (573) 751-0005.

Methods of Asexual Propagation

Six basic methods of asexual propagation are described below: budding, cutting, division, grafting, layering, and tissue culture.

Budding is similar to grafting (explained below) and is used most often to produce roses. A single bud from one plant (used as the scion) is inserted into the bark of another variety. But most greenhouse owners sell rose bushes that plant propagators have already grafted through bud grafting.

Cuttings, used predominantly with floriculture crops, are sections from the parent plant that are rooted in the growing medium to form a new plant. As illustrated in Figure 5.3, cuttings may be taken from three parts of the plant: stem tip, leaf bud, and stem section

Figure 5.3 - Cutting Locations

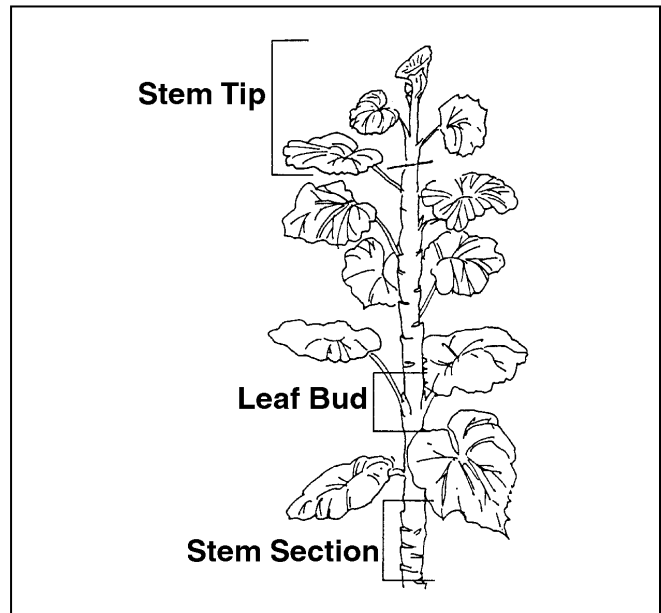

Stem tip cuttings are taken from a section or tip of the stem. This method of propagation is suited to herbaceous greenhouse plants such as carnations and chrysanthemums and various soft wood, hardwood, and semihardwood plants. Leaf cuttings are taken from a piece of the leaf or from the entire leaf, including the leaf vein or leaf bud. Leaf bud cuttings are taken from the leaf blade, petiole (stem of the leaf), and axillary bud (found in the angle between the leaf and the main stem). The cut from a stem section includes a bud and its attached leaf. Although this technique takes longer than stem tip cuttings, it produces many cuttings even with only a limited number of plants. See Figure 5.4.

Figure 5.4 - Cuttings

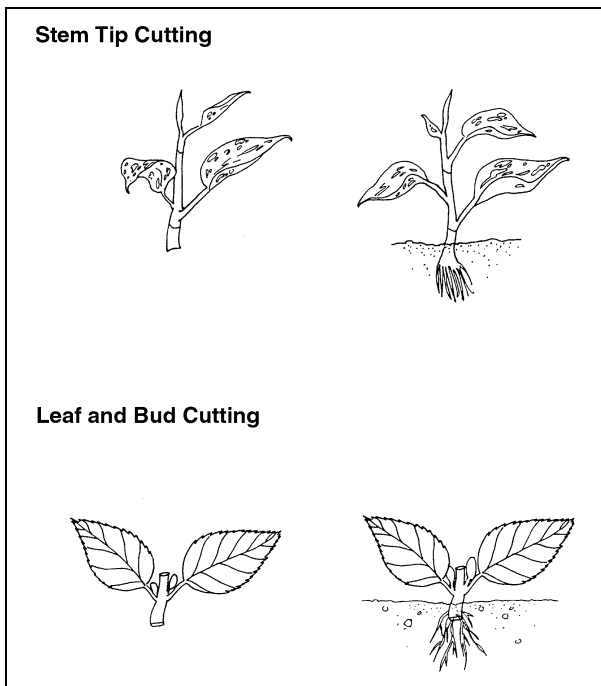

Before proceeding, the first step is to assemble clean tools, containers, and a suitable growing medium. The cutting sites, as illustrated in Figure 5.3, determine where the cut is made. For example, stem tip cuts are made with a sharp knife that removes a 2-4-inch section at the top of the plant, just below a node. The leaves are removed from the lower third to half of the cutting.

Treating the base of the cuttings with a rooting hormone enhances growth. The cuttings should be planted in a moist, soilless growing medium and placed in a high-humidity environment to reduce moisture loss. Cuttings thrive in temperatures between 65 and 75°F (18-23°C) and with a bottom heat of 75-85°F (23-29°C).

By stimulating vigorous root growth, rooting hormones increase the percentage of successfully propagated cuttings. These synthetic hormones help plants root more quickly and uniformly. They are formulated as powders and solutions. A puffer duster sprays the hormone powder on the stem. Dusting is preferred over solutions because

it enables the greenhouse owner to apply precise amounts to the base of the stem. Excessive quantities of rooting powder can rot the stem and prevent root development. In rooting hormones formulated as solutions, the base of the cutting is dipped into the hormone mix for a short period of time.

These routes for administering rooting hormones could pose a threat to the plant under certain circumstances. Pathogenic organisms can spread from diseased cuttings to healthy cuttings through the powder or solution. When applying powders, use of the puffer duster prevents infection from spreading. When rooting hormones are applied via solutions, it is wise to use only fresh ingredients and to discard all leftovers. Spraying cuttings with the solution is a safer method than dipping them.

Plant division is another method of asexual propagation. Clumps of a plant are separated into small groups. Each group has its own roots, stems, buds, and leaves or the potential to develop these parts. For plants that produce multiple crowns (e.g., Boston ferns) or offshoots, division is the easiest method of propagation. Examples of plants that naturally propagate through division are tulips, daffodils, and gladioli. See Figure 5.5.

Figure 5.5 - Division

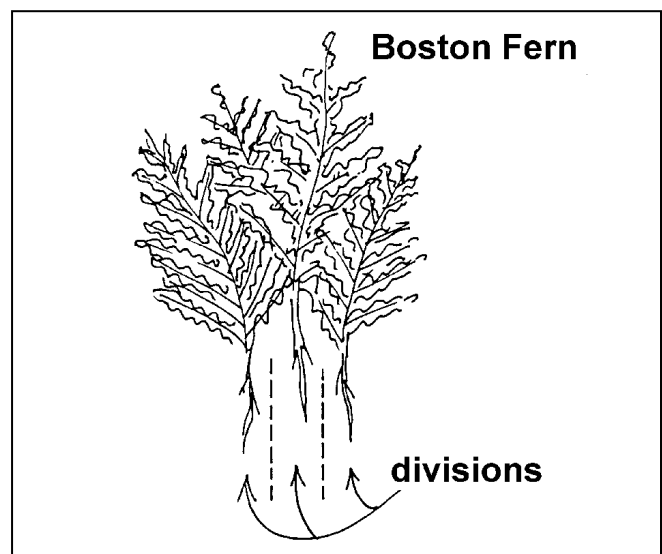

Greenhouse Operation and Management

Grafting is a propagation method in which buds, twigs, or shoots (the scion) are taken from one plant and inserted into the stems or roots of a similar plant (the rootstock), matching the cambiums in the process. Whip (or tongue) grafts join scion rootstock, whereas cleft and bark grafts join small scions to large rootstocks. This propagation technique is not prevalent in most greenhouse operations; it is used most often for developing trees. However, some flowers are grafted, such as lilacs, camellias, and azaleas. Refer to Figure 5.6.

Figure 5.6 - Grafting

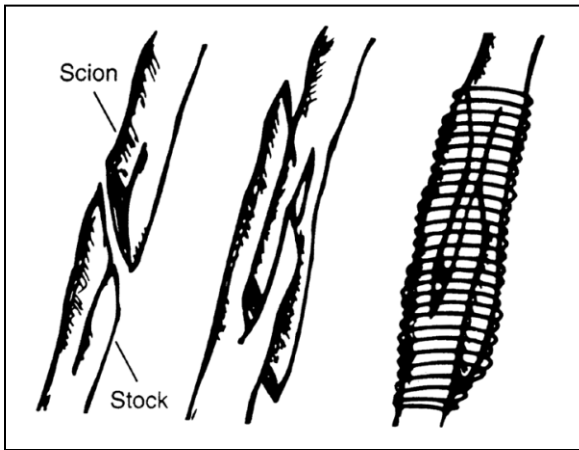

Layering is a method for propagating plants in which new roots are established while the stem stays attached to the parent plant. As the root system develops, it derives support from the parent plant until it is self-sufficient. Many houseplants are easily propagated by this method. There are several kinds of layering. Of all the types described here, the only ones commonly used in a greenhouse are simple layering and air layering (see Figure 5.7).

Figure 5.7 - Layering

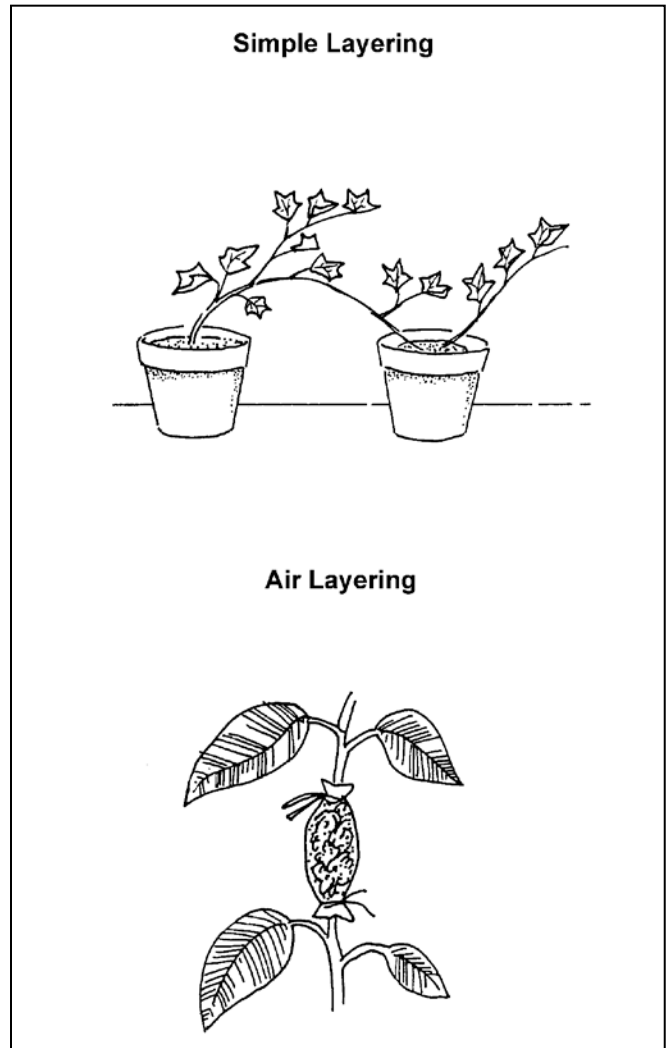

In *simple layering*, a superficial cut is made to a portion of the stem to stimulate new root growth. The wounded stem is then buried, but the tip of the stem is left exposed. Foliage plants (e.g., English ivy and rhododendrons) are commonly propagated by this method.

Air layering is also used to propagate foliage plants, such as ficus. This technique requires cutting around the stem. The wound is dusted with a hormone to induce rooting and is covered with some moist sphagnum moss, which is covered with clear plastic and then secured in place.

Tip and simple layering are similar. The terminal (end) tip is wounded, treated, and buried. However, the terminal tip is buried in the growing medium. As the tips develop, they first grow downward and eventually move upward, creating a bend. New roots develop at this juncture and the emerging tips appear above the growing medium. Raspberries, blackberries, and blueberries, which have flexible stems, are crops that are propagated by tip layering.

In *serpentine (compound) layering*, sections of the stem are alternately buried in the growing medium and exposed to the surface. This creates multiple sites for rooting. The buried portion of the stem is slightly wounded and treated with a rooting hormone.

Woody plants, such as fruit trees and roses, are propagated through *mound layering*. This involves cutting back the stem and burying the stem while it is dormant. Trench layering is also designed for propagating woody plants. After the stem has been wounded and treated with a rooting hormone, the entire plant is bent and buried in the growing medium. Only the tip is left above ground.

Tissue culture, also referred to as micropropagation, is a highly technical method in which one or more cells from the tissue of a plant are used to produce a new plant. Tiny pieces of the plant are grown in artificial media under sterile conditions. Plant development is carefully controlled through selected chemicals and growth regulators. This allows mass production of plants in a short period of time. Compared to other asexual methods of propagation used to produce a large number of crops, tissue culture is especially cost-effective and efficient.

Summary

Asexual propagation is an effective technique for increasing crop production in the greenhouse. Adequate supplies, a suitable growing environment, and an effective labeling system are essential. Each propagation method - budding, cutting, division, grafting, layering, and tissue cultures - offers unique features that can boost the greenhouse owner's inventory. Foliage and ornamental plants are propagated by herbaceous cuttings, division, and simple and air layering. The greenhouse owner can promote successful, healthy plant development by applying correct amounts of rooting hormones.

Credits

Boodley, James W. *The Commercial Greenhouse*, 2nd ed. Albany, NY: Delmar Publishers, 1996.

Cooper, Elmer L. *Agriscience: Fundamentals & Applications*, 2nd ed. Albany, NY: Delmar Publishers, 1995.

Greenhouse Operation and Management (Student Reference). University of Missouri-Columbia: Instructional Materials Laboratory, 1990.

Lee, Jasper S., Series Editor. *Introduction to Horticulture*, 3rd ed. Danville, IL: Interstate Publishers, Inc., 2000.

"2002 Missouri Certified Nursery and Greenhouse Directory." Missouri Plant Law (Sections 263.010-263.180). Plant Industries Division, Missouri Department of Agriculture. <<http://www.mda.state.mo.us/pd/NurseryBook.pdf>> accessed 5/10/02.

Unit VI: Plant Health

Lesson 1: Greenhouse Pests and Diseases

The very features that nourish greenhouse crops - warmth, moisture, humidity, and controlled lighting - also encourage destructive pests and support diseases. This unit examines various issues concerning plant health. Lesson 1 identifies greenhouse pests, describes their effects on plants, outlines causes of diseases, and gives examples of infections that attack plants.

Descriptions of Pests

A greenhouse pest is any life-form that causes injury or loss to plants. The major pests are insects, arachnids (eight-legged invertebrates, e.g., mites, spiders, millipedes, and centipedes), nematodes, rodents, mollusks, weeds, and disease-causing organisms. Of those listed, insects and mites pose the greatest threat to greenhouse crops. These pests gain access to cultivated crops through open doors, when new produce arrives, and through ventilation ducts.

Effects of Insects and Mites

By attacking the plant's vascular system, leaves, and roots, insects and mites interfere with vegetative functions and reduce the rate of development. A defining characteristic of these pests is how they feed on plants, which is determined by the shape and movement of their mouth parts, as shown in Figure 6.1. Chewing insects like grasshoppers devour leaves and roots and destroy the plant's tissues. Piercing-sucking and rasping-lapping pests puncture the plant and then suck out life-sustaining sugary sap from the phloem cells. Vector pests introduce diseases.

Figure 6.1 - Types of Mouth Parts

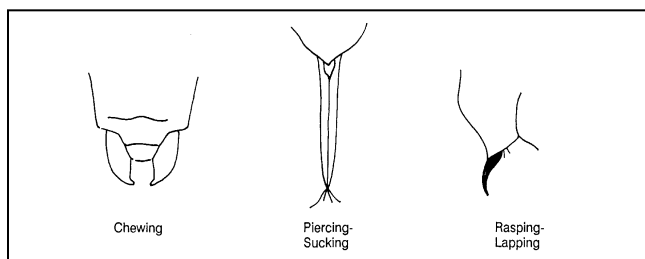

Identifying the specific stage of the pests' life cycle helps determine when to apply the appropriate treatment. Some pests invade crops as adults; others are destructive as larvae or nymphs. This growth process, known as metamorphosis, can be gradual or complete. During gradual metamorphosis, the pest undergoes three phases: egg, nymph, and adult. The insect molts several times during the nymph stage until it reaches adulthood, as illustrated in Figure 6.2.

Figure 6.2 - Gradual Metamorphosis

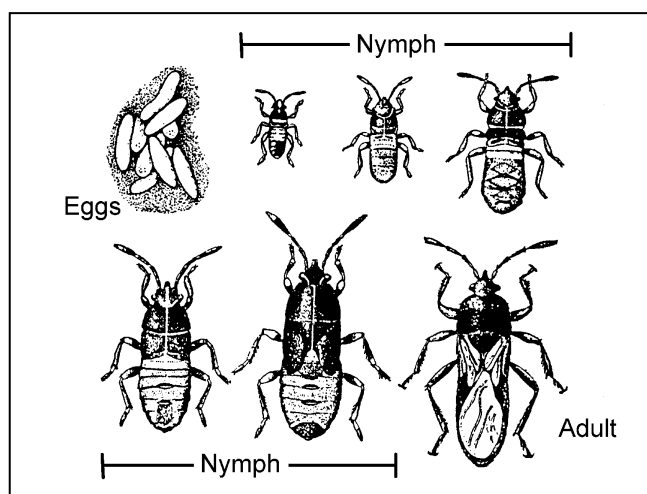

Greenhouse Operation and Management

Egg, larva, pupa, and adult are the four stages of complete metamorphosis (see Figure 6.3).

Figure 6.3 - Complete Metamorphosis

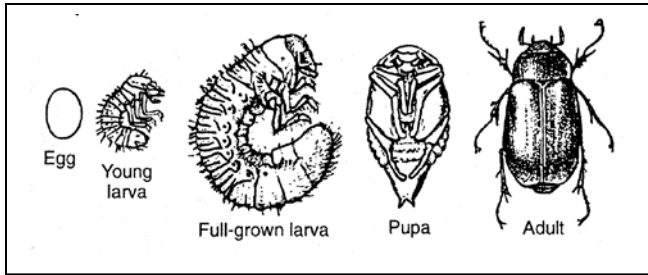

Aphids are common pests in the greenhouse. The species most prevalent is the green peach aphid that not only harms leaves but also spreads bacteria and viral diseases. Adults are 1/25-1/8 inch (1-3 mm) long. Their piercing-sucking mouth parts suck plant sap from the phloem cells. This stunts and distorts new shoots. Tiny yellow spots appear on the foliage, and a sugary substance develops called “honeydew” (not to be confused with melon). The honeydew nourishes black sooty mold. Because females can reproduce as many as 100 offspring within 3 days, aphids are an ever-present threat to ornamentals and vegetable crops. (See Figure 6.4.)

Figure 6.4 - Aphid

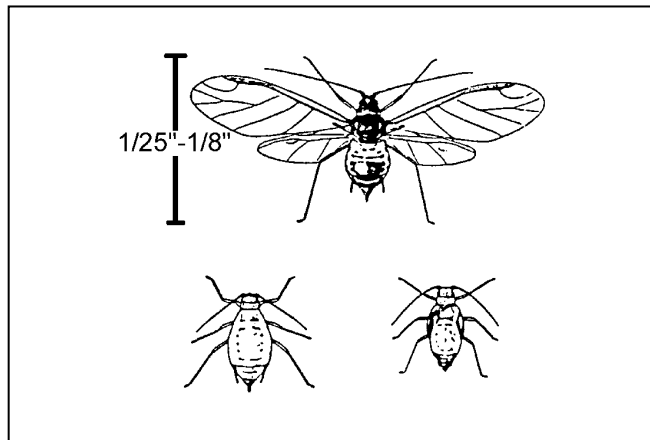

It is during its larval, not adult, stage that fungus gnats damage plants. At 1/4 inch (6 mm), these larvae, which live in the soil, use their chewing mouth parts to demolish roots, root hairs, and

crowns of bulbs or plants. The harmful results are evident in seedlings: stunted growth, lack of plant vigor, wilted leaves, leaf drop, and yellow foliage. The female adult spends her 10-day life span producing 300 eggs, which are laid in moist, fertile soil. Figure 6.5 illustrates the life stages of the fungus gnat.

Figure 6.5 - Fungus Gnat

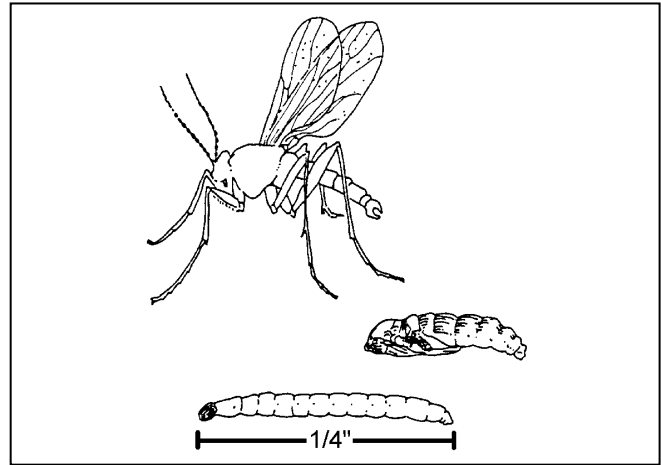

Adult mealybugs are 1/8-3/8 inch (3-4 mm) long. They use their piercing-sucking mouth parts to drain the sap, resulting in diminished plant vigor, yellow and deformed foliage, and leaf drop. Covered with a waxy, white powder, mealybugs lay their eggs in leaf axils and under leaves. When the egg clusters develop, they look like tiny cotton balls. Figure 6.6 shows an adult mealybug.

Figure 6.6 - Mealybug

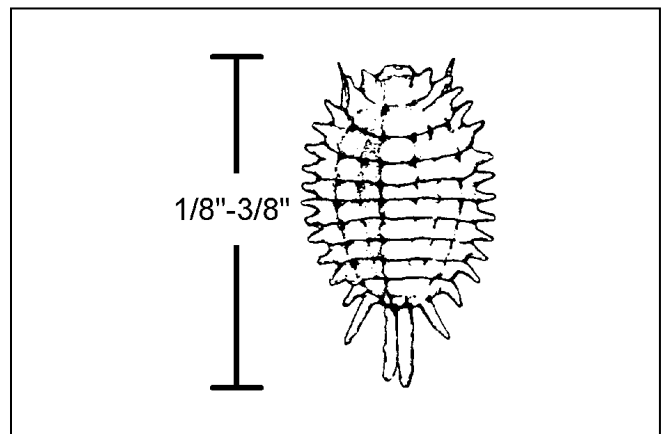

Other pests that use piercing-sucking mouth parts are scale insects. Adults are 5/16 inch (8 mm); some have a round, hard shell that has a waxy, rubbery coating. Hard-coated scale insects exude honeydew. When a plant is attacked by scale, symptoms include a lack of vigor, stunted growth, and yellowed leaves. See Figure 6.7.

Figure 6.7 - Scale

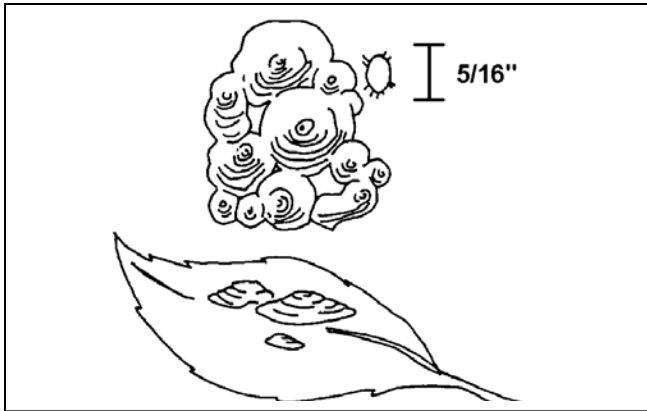

When it is warm outside, huge quantities of thrips may gather and fly into the greenhouse at the first opportunity. Adults are only 1/25 inch (1 mm); they use their rasping-lapping mouth parts to scrape leaf surfaces and petals and then drink the sap that is released. New growth and flowers become malformed, flower petals get streaked and turn brown, and eventually the leaves and flowers drop off. When thrips invade, they can spread viral diseases among plants. Figure 6.8 shows the life cycle of thrips.

Figure 6.8 - Thrips

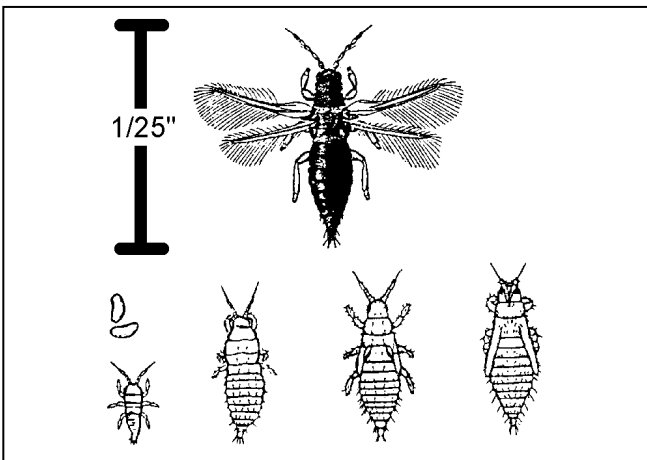

Whiteflies look like tiny moths and feed on popular greenhouse plants: poinsettias, chrysanthemums, and bedding plants. Adults are 1/16 inch (2 mm) and have piercing-sucking mouth parts. Evidence of damage from whiteflies is tiny yellow spots on foliage. They also can spread disease among plants by emitting honeydew. See Figure 6.9.

Figure 6.9 - Whitefly

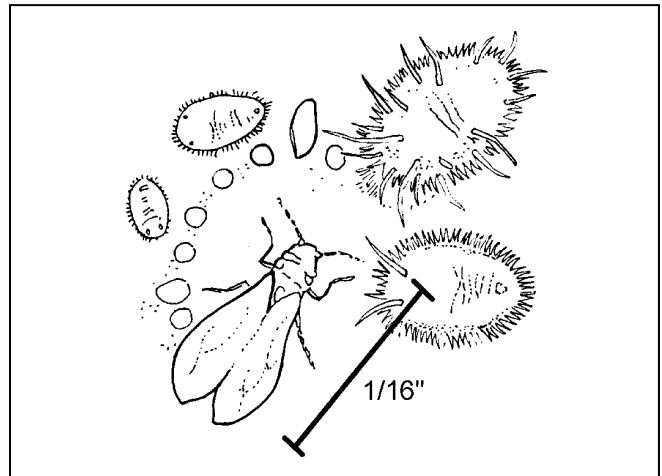

Many species of mites (arachnids) injure plants. Mites are very tiny - less than 1/50 inch (0.50 mm) long - and have piercing-sucking mouth parts. Spider mites (illustrated in Figure 6.10) are especially prevalent in the greenhouse. Like their namesake, these arachnids weave miniscule webs on the plant that turn the leaves brown. When mites attack, the foliage develops tiny yellow spots, a bronze hue, and it curls up. When the beauty of a plant is marred, the greenhouse owner suffers economic loss. Mites are difficult pests to control because their resilience makes them able to adapt to various temperatures and humidity levels.

Greenhouse Operation and Management

Figure 6.10 - Spider Mite

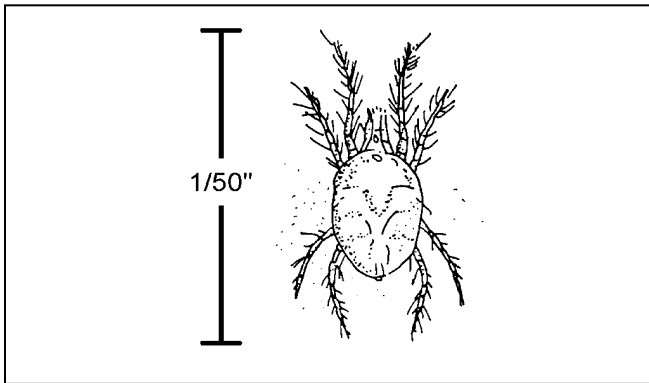

Effects of Other Pests

Nematodes are wormlike invertebrates that live in the soil. Many are plant parasites. Those that are harmless to crops are still a threat because they penetrate root cells, giving fungi and bacteria an opportunity to enter.

Although rodents, birds, and other mammals don't typically enter an enclosed greenhouse, if they do gain access, they harm plants by eating plant parts and digging up the soil. Mollusks such as snails and slugs use their chewing mouth parts to feed on leaves and young stems. With voracious appetites, these pests can devour all the foliage on greenhouse plants if they are not controlled. Creating damage exclusively at night, snails and slugs leave a slimy trail everywhere they go. Figure 6.11 depicts these additional pests.

Figure 6.11 - Other Pests

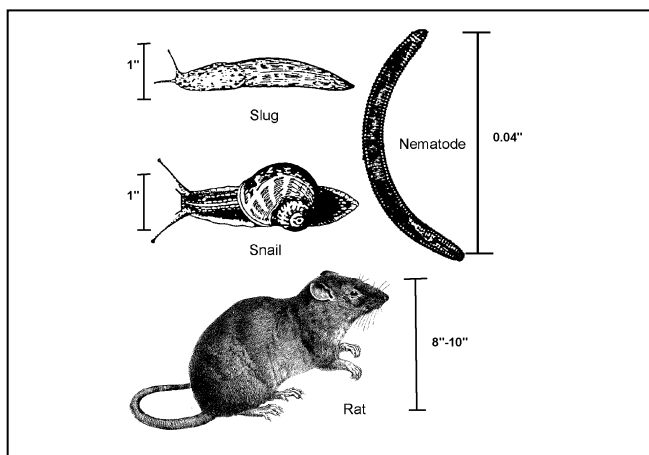

Weeds are any unwanted plants that grow out of place. The problem with weeds is that they compete with cultivated plants for space, light, water, and nutrients. Additionally, they may support pests and diseases that can infect cultivated plants. The greenhouse owner's profit margin is substantially diminished if weeds are allowed to choke out emerging crops.

Causes and Sources of Disease

There are two basic causes of plant diseases: cultural and parasitic. Cultural diseases result from incorrect applications of chemicals in the growing medium or on the plants, nutritional deficiencies, and physical damage to plant parts. The greenhouse's internal environment may also promote disease. For example, if the humidity is too high, pathogenic spores can germinate. Poor drainage in plant containers also invites disease.

Microorganisms cause parasitic diseases. The parasites are contagious and can sweep rapidly through the greenhouse, devastating valuable crops. Pathogenic microorganisms include viruses, bacteria, and fungi. Viruses cause the most difficult type of disease to control and treat. Plants suffer from stunted growth or die. Viruses usually attack the plant's vascular system. This means that the crop yield and the quality of the produce are substantially reduced. Sucking insects as well as unsterile equipment and tools used during asexual propagation transmit viral infections throughout the greenhouse.

Harmful bacteria enter the plant through openings in the epidermis, flowers, stem, and leaves. Bacteria rob the nutrient solution of life-supporting oxygen.

Fungi are the most common cause of plant disease. Fungal spores grow on and inside of plants and they spread via water, air, and insects. If an ornamental plant is pruned with clippers that have been exposed to a fungus, the plant gets

infected as well. Any wounded plant part is vulnerable to fungal attack.

The greenhouse may contain several potential sources of disease. Infected or poorly drained soil hosts a variety of pathogens. Debris from previous crops may already be infected and could spread disease-bearing organisms via the air. Polluted water or air and pathogenic plant tissues from cuttings may also harbor diseases.

Common Diseases

Greenhouse crops frequently suffer from damping-off. This disease is caused by a complex of organisms that most often includes the soilborne fungi *Phytophthora* or *Rhizoctonia*. Damping-off usually attacks seedlings. The fungi originate in the soil or seed itself. At preemergence, the seed is destroyed before germination. At postemergence, the seedling falls over and is destroyed at the soil level.

Fungi also cause Botrytis blight (gray mold). This is a costly disease because it ruins popular crops such as roses, azaleas, geraniums, and poinsettias. It thrives in a cool, humid environment, which is readily provided in the greenhouse. Plant symptoms are gray spots on the foliage. The tissue under the spots turns soft, then brown, then becomes completely rotten.

Bacteria or fungi cause leaf spot and other foliar diseases. If bacteria are the cause, the plant must be discarded; if fungi are the cause, the plant can be treated. These diseases also develop in a humid environment. Plants with leaf spot have discolored and distorted leaves.

Root rot is caused by bacteria or *Pythium* and *Phytophthora* fungi. Houseplants die most frequently of this disease. Root rot results from overwatering. Overwatering causes damage to the roots and this enables fungi to invade the plant. Consequently, there is a decrease in both the uptake of water and in the root hairs' ability to

transmit dissolved nutrients into the plant. When plants get root rot, the roots become brown or black and there are less of them. They become slimy and have a foul odor. The leaves yellow, wilt, and finally drop off.

Summary

The greenhouse environment unfortunately can support a variety of pests. By understanding their life cycle, the greenhouse owner can plan effective treatments for eradication. Viruses, bacteria, and fungi are responsible for causing diseases such as damping-off, Botrytis blight, and root rot.

Credits

Acquaah, George. *Horticulture: Principles and Practices*. Upper Saddle River, NJ: Prentice Hall, 1999.

Boodley, James W. *The Commercial Greenhouse*, 2nd ed. Albany, NY: Delmar Publishers, 1996.

Cooper, Elmer L. *Agriscience: Fundamentals & Applications*, 2nd ed. Albany, NY: Delmar Publishers, 1995.

Greenhouse Operation and Management (Student Reference). University of Missouri-Columbia: Instructional Materials Laboratory, 1990.

Lee, Jasper S., Series Editor. *Introduction to Horticulture*, 3rd ed. Danville, IL: Interstate Publishers, Inc., 2000.

Nelson, Paul V. *Greenhouse Operation and Management*, 3rd ed. Reston, VA; Reston Publishing Company, Inc., 1985.

Unit VI: Plant Health

Lesson 2: Pest Control

The last lesson summarized types of insects, mites, animals, and diseases that threaten greenhouse-grown plants. To ensure healthy crop production and a profitable yield, the greenhouse owner must understand how to control these pests. This lesson describes several methods of plant protection.

Pest Control Basics

The purposes of a pest control program are to prevent entrance of pests inside the greenhouse, reduce or eliminate pest populations, protect plants from pests already present, and increase plants' resistance to pests. The basic methods of control are biological, chemical, cultural, and mechanical, as discussed below.

Biological Pest Management

The principle of biological pest management is to use living organisms that are natural predators of pests. For examples, ladybugs prey on aphids. The bacterium *Bacillus thuringiensis* kills harmful worms, and trap plants lure pests away from cultivated crops. Biological controls tend to take longer than the other methods and they do not completely eliminate greenhouse pests.

Chemical Pest Management

Chemical management can be used to protect and treat plants and to destroy pests. Herbicides kill weeds that hinder growth. Chemicals are effective, but several pests have developed resistance to some brands. Also, many types of pesticides are under review by governmental agencies, such as the Environmental Protection Agency (EPA). Because the promulgation of pesticide regulations can occur unnoticed, the greenhouse owner must keep apprised of which

chemicals may be used and how those pesticides affect living organisms. An EPA web site (<www.epa.gov/pesticides/label>) displays interactive labels of various pesticides that identify their ingredients and/or risk factors. Types of pesticides designed to eliminate specific pests are listed in Table 1. Please note that each of these chemical controls can be deadly and must be used with extreme caution.

Table 6.1 - Pesticides for Specific Pests

Type of Pesticide	Pests Treated
Acaricide	Spiders, ticks
Aviicides	Birds
Bactericide	Bacteria
Fungicide	Fungi
Insecticides	Insects
Miticides	Mites, ticks
Molluscides	Snails, slugs
Nematicides	Nematodes

Cultural Pest Management

The cultural management approach applies techniques used in the greenhouse to ensure a high-quality growing environment. This involves mulching and pruning plants, pasteurizing growing media, and purchasing quality seeds. Selecting pathogen-resistant plant varieties and planting at suitable times also help control pest attacks. Cultural practices that affect plant growth and potential exposure to pests include fertilization, irrigation, and aeration.

Mechanical Pest Management

Pests can be prevented, removed, and destroyed by mechanical (physical) management. Helpful activities include weeding and mulching, handpicking large bugs from plants, screening out

Greenhouse Operation and Management

insects, and hanging flytraps. Maintaining sanitation throughout the greenhouse deters pests. Propagation benches, tools, and the floor must be cleaned frequently. All employees must ensure that they do not contaminate crops by stepping on benches.

Integrated Pest Management

As its name implies, integrated pest management (IPM) is a comprehensive strategy that combines features of biological, chemical, cultural, and mechanical pest management programs. The goals of IPM focus on reducing the following: the number and impact of pests (but not necessarily to eradicate all of them); economic loss due to pests; reliance on pesticides; and safety hazards to humans, animals, plants, and the environment. Operating from an ecological perspective, IPM seeks natural solutions to pest management. IPM strategies develop from careful decision making and planning. Fundamental to IPM is a thorough understanding of pertinent biological information about pests in the greenhouse. This includes knowing the pests' life cycle, behavior, mouth types, and other characteristics. Next, the greenhouse owner must identify the types of pests that injure greenhouse crops and know how to recognize symptoms of plant injury. Then the owner establishes a certain level of damage that is considered unacceptable. This threshold signals when IPM strategies are implemented. At this point, a series of important issues are resolved, as illustrated in Table 6.2.

Table 6.2 - IPM Decision-Making Process

Responses to Unacceptable Levels of Pest Damage
1. Start preventative strategies.
2. Scout plants for symptoms or presence of pests.
3. Determine if pests are present.
4. Identify pests and scope of damage.
5. Treat plants.
6. Evaluate effectiveness of treatment.
7. Evaluate management strategies.

Pest control is achieved through early detection and application of safe eradication measures. Greenhouse owners need to constantly monitor and evaluate the efficiency of IPM by keeping accurate records that track the following:

- Range of daily temperatures
- Amount of pests on plants and their current developmental stage
- Status of plant growth and root health
- pH and soluble salt level of the growing medium

IPM incorporates strategies known as “*best management practices*” (BMPs). The purpose of BMPs is to incorporate scientific techniques and real-world experience to maintain cost-efficient operations and ensure high-quality crops. BMPs are environmentally friendly approaches to pest management. Examples of BMP practices that promote IPM goals are listed in Table 6.3.

Table 6.3 - Best Management Practices That Control Pests

Best Management Practices
Testing growing media
Determining correct time and application of fertilizers
Ensuring proper drainage
Managing irrigation systems
Using controlled-release fertilizers
Using natural (biological) pest controls
Using cultural pest controls

Summary

Protecting greenhouse crops from destructive pests results in commercial success for the greenhouse owner. Biological, chemical, cultural, and mechanical management methods have distinct features for controlling pests. The integrated pest management strategy incorporates aspects of all of these approaches and is ecologically sensitive to the growing environment.

Credits

Acquaah, George. *Horticulture: Principles and Practices*. Upper Saddle River, NJ: Prentice Hall, 1999.

Boodley, James W. *The Commercial Greenhouse*, 2nd ed. Albany, NY: Delmar Publishers, 1996.

Cooper, Elmer. *Agriscience: Fundamentals & Applications*, 2nd ed. Albany, NY: Delmar Publishers, 1995.

Greenhouse Operation and Management (Student Reference). University of Missouri-Columbia: Instructional Materials Laboratory, 1990.

“Integrated Pest Management for Greenhouse Crops.” Appropriate Technology Transfer for Rural Areas. <<http://www.attra.org/attra-pub/gh-ipm.html>> accessed 2/20/02.

Lee, Jasper S. Series Editor. *Introduction to Horticulture*, 3rd ed. Danville, IL: Interstate Publishers, Inc., 2000.

PA IPM News, Volume 3, Number 2, Spring 2000. <<http://paipm.cas.psu.edu/NewsLetter/PAIPMnews9.html>> accessed 2/20/02.

Unit VI: Plant Health

Lesson 3: Pesticide Use and Safety

As potent weapons in the arsenal against pests, chemical deterrents can systematically destroy vermin from plants. However, personnel authorized to apply pesticides must be keenly aware of the environmental consequences to greenhouse employees, crops, and even to the equipment. This lesson first addresses pesticide use: label information, forms of pesticides, application methods, and modes of action. The discussion then focuses on basic safety issues, beginning with a definition of toxicity levels. Lesson 3 continues to examine safety by defining storage and disposal procedures, personal protection measures, and first aid for accidental poisoning. Finally, sources of pesticide-related information and pesticide certification procedures are provided.

Pesticide Label

One of the most crucial features of a pesticide is its label. Essentially a legal document, the label prescribes acceptable methods of usage, storage, and disposal; it controls how the product is sold and distributed. If poisoning occurs, doctors refer to the label for treatment data.

Authorized pesticide users must scrupulously read and adhere to all label information and directions concerning usage, storage, and disposal. The label warns users where the product could enter the unprotected body. Additional information identifies required personal protective clothing and correct use of equipment. The label also lists environmental, physical, or chemical hazards and indicates toxicity to certain plants or animals. Other information includes the pesticide's EPA classification and a safe reentry time that states when employees can enter the greenhouse without protective clothing and equipment. Figure 6.12 displays a sample pesticide label.

Figure 6.12 - Sample Pesticide Label

7. RESTRICTED USE PESTICIDE
(GROUND AND SURFACE WATER CONCERNS)
FOR RETAIL SALE AND USE ONLY BY CERTIFIED APPLICATORS OR PERSONS UNDER THEIR DIRECT SUPERVISION, AND ONLY FOR THOSE USES COVERED BY THE CERTIFIED APPLICATOR'S CERTIFICATION.

8. Bug-B-Ded Insecticide
14. 6EC

9. Active Ingredient:
Killazine (2, 4, 6 diamizine) 37.4%
Inert ingredients: 62.6%
Total: 100.0%

1 gal. contains 6.0 lb. killazine
10. 2.5 GALLONS
U.S. Standard Measure
11. EPA Reg. No 100-358
12. EPA Est. 34704-MI-1

3. Statement of Practical Treatment
If **swallowed**, DO NOT induce vomiting. Call a physician or Poison Control Center immediately.
If **in eyes**, flush with plenty of water.
If **on skin**, wash with plenty of soap and water.
NOTE TO PHYSICIAN: vomiting should only be induced under professional supervision.

17. Directions for Use
It is a violation of federal law to use this product in a manner inconsistent with its labeling.

Agricultural Use Requirements

Use this product only in accordance with its labeling and with the Worker Protection Standard, 40 CFR part 170. **Do not enter or allow worker entry into treated areas during the restricted-entry interval (REI) of 4 hours.** PPE is required for early entry to treated areas that is permitted under the Worker Protection Standard and that involves contact with anything that has been treated, such as plants, soil, or water is:
• Coveralls • Waterproof gloves • Shoes plus socks

1. Keep out of the reach of children
2. CAUTION
4. Harmful if swallowed or absorbed through the skin. Causes minor skin irritation.

5. Personal Protective Equipment (PPE):
Applicators and other handlers must wear:
• Long sleeved shirts
• Chemical resistant gloves
• Shoes plus socks

6. Environmental Hazards
This product is toxic to fish. Do not apply directly to water or to areas where surface water is present.

15. Physical or Chemical Hazards
Do not use or store near heat or open flame.

18. Storage and Disposal
Storage: Do not contaminate water, food, or feed by storage or disposal. Store at temperatures above 32°F.
Pesticide Disposal: Wastes resulting from the use of this product may be disposed of on site or at an approved waste disposal facility.
Container Disposal: Triple rinse (or equivalent). Then puncture container and dispose of in a sanitary landfill or incinerate.

16. Limited Warranty and Disclaimer:
The manufacturer warrants that this product conforms to the chemical description on the label; that this product is reasonably fit for the purposes set forth in the directions; that the directions, warnings, and other statements on this label are based upon responsible experts' evaluation of reasonable tests of effectiveness, of toxicity to laboratory animals, and to plants, and of residues on food crops and upon reports of field experience.

Cool-season turf: Chinch bugs, fleas and mole crickets: apply 1 ounce of product per 1000 square feet.
Warm-season turf: White grubs: apply 2 ounces product per 1000 sq. ft. and water in with supplemental irrigation. Allow at least 10 days before making a second application.

13. BUGS-R-US Inc.
1468 North-South Expressway
P.O. Box 5600
Research Triangle Park, NC 123451.

Key to Numbering

<p>1. Child hazard warning. 2. Signal word. 3. Statement of practical treatment 4. Hazards to humans and domestic animals 5. Personal protective equipment 6. Environmental hazards 7. Use classifications 8. Brand (trade) name 9. Ingredient statement</p>	<p>10. Net contents 11. EPA registration number 12. EPA establishment number 13. Name and address of manufacturer 14. Formulation 15. Physical or chemical hazards 16. Limited warranty and disclaimer 17. Directions for use 18. Storage and disposal</p>
--	--

Pesticide Toxicity Levels

Each chemical listed on a pesticide label contributes key ingredients that target designated pests. The cumulative effect of all chemicals in a specific pesticide is its toxicity level. Pesticide toxicity levels are measured in terms of LD (lethal

Greenhouse Operation and Management

dose). The calculations of LDs are based on test mammal populations. An LD₅₀ refers to the amount of pesticide required to kill 50% of a test population within 2 weeks. LD₅₀ is expressed in milligrams per kilogram of the test animal's body weight. The lower the LD₅₀ value, the higher the pesticide's toxicity. Low LD₅₀ values indicate that small amounts of the pesticide provide a lethal dose.

A pesticide's toxicity may be transmitted by the following means: oral (ingested), inhaled (breathed), and dermal (absorbed through skin).

Toxicity levels are communicated by signal words on pesticide labels. "Caution" means the product is slightly toxic and has an LD₅₀ of 500-5,000.

"Warning" denotes a moderately toxic product; its LD₅₀ is 50-500. "Danger" or "Danger - Poison" is the most toxic level. The words are printed in red and accompanied by a skull and crossbones drawing. Its LD₅₀ is 0-50. After the signal word on every pesticide label, the following statement must appear in large print: "Keep Out of Reach of Children."

Forms of Pesticides

Pesticides are either liquid or dry. The liquid forms are aerosols, emulsifiable concentrates, encapsulated, or flowable. Table 6.4 summarizes how each form is designated and used.

Table 6.4 - Liquid Forms of Pesticides

Form of Liquid	Designation	Usage
Aerosols	A	Pressured cans or aerosol bombs
Emulsifiable concentrates	EC	Mixed with water in spray tank
Encapsulated	Pesticide sealed in microcapsules	Time release - mixed with water
Flowable	For L	Mixed with water

Dry pesticides come in several forms: bait, dust, granular, soluble powder, wettable powder, and dry flowable, as summarized in Table 6.5.

Table 6.5 - Dry Forms of Pesticides

Form of Liquid	Designation	Usage
Bait	B	Pesticide-laden substance that lures pests
Dust	D	Pesticide and inert ingredients ground into dust; applied dry
Granular	G	Same composition as dust, but larger particles; applied dry
Soluble powder	S or SP	Finely ground ingredients; dissolved in water
Wettable powder	W or WP	Mixes with water in spray tank; must be constantly agitated to keep mixed
Dry flowable	DF	Dry granules of pesticide; less dust than powders

Application Methods

Pesticides can be applied at key stages in the plant's growth cycle. Seeds, bulbs, corms, and

tubers benefit from applications of pesticides to control soilborne pathogens that rot seeds or induce damping-off. To rid the growing media of nematodes and other soilborne pests, granular and

Greenhouse Operation and Management

dust forms of pesticides are effective. If pruning creates a wound in the plant, apply a liquid or dust pesticide directly to prevent further damage to a plant's foliage. To prevent crops from decaying during storage, apply a postharvest pesticide. Figure 6.13 depicts equipment used to apply pesticides

Figure 6.13 - Types of Sprayers Used to Apply Pesticides

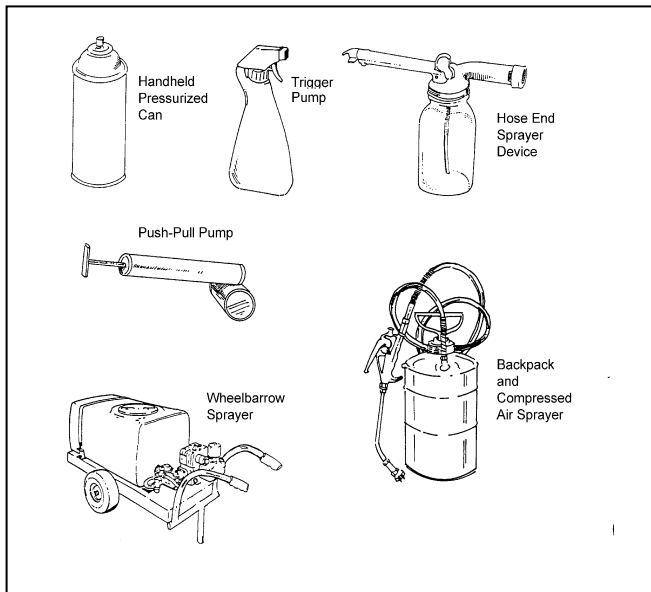

Aerosol generators and foggers fill the greenhouse with a mist of pesticides that are either broken down by very fine nozzles under high pressure (cold fogger) or are vaporized by a generator that uses heat.

Authorized personnel maintain a pesticide application log to denote where the pesticide is applied, the active ingredients in the product, its EPA registration number, and dates of application and safe reentry. The log also notes the types of Personal Protection Equipment required. See Figure 6.14 for a sample pesticide application log.

Figure 6.14 - Sample Pesticide Application Log

Procedure	Application #1	Application #2
Area Treated: Location & Description		
Product Name		
EPA Registration Number		
Active Ingredient: Common or Chemical Name		
Date of Application: Month/Day/Time		
Entry Restricted Until: Month/Day/time		
Requirement to Post When Area Is Treated? Yes/No		
Requirement to Give Oral Notification? Yes/No		
PPE Requirements for Handlers		
Early Entry PPE Required for Workers		
Other Label Requirements to Protect Workers and Others		

Modes of Action for Pesticides

Pesticides act in distinct ways. Biological controls, as mentioned in Lesson 2, use living organisms to kill plant pests. Biopesticides are created from cultured microorganisms and plants and are used in aerial sprays to control diverse

Greenhouse Operation and Management

soilborne diseases as well as harmful bacteria and fungi.

Several products can eliminate pests. Contact pesticides are fatal to the insects' nervous and respiratory systems and immediately kill them upon exposure. Fumigants are poisonous gases released in a sealed greenhouse and kill insects as they breathe or absorb the chemicals. All employees must vacate the premises when these chemicals are released. Growth regulators that have intense concentrations of specific hormones adversely affect pest development.

Researchers have developed pest deterrents from pheromones. These are natural chemicals that some female insects produce to attract male insects. Scientists manipulate this attraction by using pheromones to lure the male insects into traps where they die. Alone, the females are unfertilized; consequently, the targeted insect population plummets.

Protectants prevent fungal pests from entering or damaging the surface of plants and should be uniformly applied over the entire plant. Stomach poisons kill pests when the insects eat or swallow the treated plant. Systemics are pesticides that the plant absorbs and then translocates to all its parts via the vascular system. The pest is killed as it feeds on the plant.

Pesticide Safety Issues

Because chemical pesticides are powerful substances, they must be handled with extreme caution. Pesticides are potentially lethal to human and animals. Used irresponsibly, pesticides contaminate air, water, and food and they pollute the environment. It is important to adhere to all federal, state, and local laws and guidelines and ensure personal safety and protection of others.

In 1992, the EPA issued the Worker Protection Standard (WPS). This regulation covers pesticides used in agriculture: farms, forests,

nurseries, and greenhouses. The goal of the WPS is to reduce the risk of pesticide-related illness and injury. Employers of people handling pesticides are required to provide information on pesticide exposure, protection against exposure, and ways to alleviate exposure to pesticides. For employees, WPS information provides safety training, safety posters, and access to specific information on pesticides used on-site. This regulation also keeps the pesticide handler and other employees from inadvertent exposure. The WPS regulation requires decontamination sites and emergency assistance for a worker or handler who is poisoned or injured by a pesticide.

General Pesticide Storage and Disposal Procedures

Adhering to correct pesticide storage procedures is an important aspect of pesticide safety. Read and follow the pesticide label for storage instructions and be aware of general pesticide storage safety guidelines. Store in the original containers, making sure labels are visible and marked with the date of purchase. Pesticides should not be stored near food, medicine, or other supplies. Keep chemicals away from flammable materials and routinely check containers for leaks or damage. Ensure that cleanup materials are close by.

To dispose of pesticides and pesticide containers, read and follow the label for instructions and precautions. General pesticide disposal guidelines stipulate that pesticides should not be flushed down drains, into sewers, or in waterways. Follow proper disposal procedures for old or unwanted products. Observe mandates from the U.S. Department of Agriculture and the EPA. For specific, local pesticide laws and guidelines, contact the State Department of Natural Resources.

Personal Protection Measures

The first step in personal protection is to obtain proper education and permits for pesticide use. Use Personal Protective Equipment (PPE), which may consist of any or all of the following: goggles, respirator, long sleeves rolled over long rubber gloves, hat, rubber boots, and overalls or coveralls secured with a band over boots. The following guidelines concern how to apply pesticides safely:

- Select the safest, least toxic substance possible.
- Use approved products only for intended purpose.
- Mix only the amount needed.
- Apply with extreme caution.
- Use proper equipment and clothing.
- Review label carefully.
- Know and follow proper application procedures.
- Know how to handle accidental poisoning.
- Do not eat, drink, or chew anything during or immediately after application.
- Ensure adequate ventilation and clear the area of people, animals, and items.
- Clean all equipment and clothing.
- Thoroughly wash skin with cleaner and water.

Handling Accidental Pesticide Poisoning

If a greenhouse worker accidentally ingests a pesticide, first observe the victim's symptoms, which vary according to the type and amount of pesticide, length of exposure, interval between exposures, and the employee's general health.

External irritants affecting outer tissues may cause pesticide poisoning. Symptoms include stinging in the eyes, ears, throat, nose, mouth, or other external tissues. Internal poisons are absorbed into the body through the mouth or skin and may cause injury to internal body organs.

If either type of pesticide poisoning occurs, immediately follow basic first aid procedures. Act quickly and remove the victim from the contaminated area. Also remove his or her contaminated clothing. Generously flood the affected area with water. Contact a doctor or the poison control center and administer first aid as directed.

Sources of Pesticide Information and Recommendations

The greenhouse owner should maintain current information about the pesticides used in the greenhouse. Reliable sources include university Extension offices, federal and state departments of agriculture, and pesticide suppliers.

Certifications Required to Use Pesticides

In Missouri, certification is required for anyone who wants to use pesticides. Users are designated as certified applicators and operators. These are the various categories: Commercial Applicators, Certified Noncommercial Applicators, Public Operators (government employees), Private Applicator Licenses, Pesticide Technician Licenses, and Pesticide Dealer Licenses.

Applicants seeking certification must pass state pesticide certification examinations that are part of the General Standard of Competence (CORE) examination and at least one category exam that reflects the applicant's specialized technical expertise. In order to take these exams, the applicant must first send the Certified Applicator and Pesticide Dealer Application to the Missouri Bureau of Pesticide Control. To help prepare for these tests, the applicant may buy a study manual from the University of Missouri Extension Publications (800-292-0969).

The applicant has to satisfy additional requirements after passing the exams based on the type of license desired. Specific information is

Greenhouse Operation and Management

available from the Missouri Department of Agriculture, Plant Industries Division, Bureau of Pesticide Control, P.O. Box 630, Jefferson City,

MO 65102. Phone: 573-751-5504; Fax: 573-751-0005.

Specific information relating to certification expiration and recertification is summarized in Table 6.6.

Table 6.6 - Certification Expiration and Recertification

Type of Certificate	Date of Expiration	Recertification Process
Certified Commercial Applicator	Annually	\$50 license fee (as of 2002; check with Bureau of Pesticide Control for updates); submit signed renewal card before expiration
Certified Noncommercial Applicator	Annually	\$25 license fee (as of 2002; check with Bureau of Pesticide Control for updates); submit signed renewal card before expiration
Certified Public Operator	Every 3 years	No license fee (as of 2002; check with Bureau of Pesticide Control for updates); submit signed renewal card

By law, every 3 years all Certified Applicators and Operators must renew their certifications. Individuals may take the exams again or enroll in an approved recertification program. Sample facilities offering training are the University of Missouri Cooperative Extension Service (available every January) and various businesses, groups, and associations. The Bureau of Pesticide Control must approve all recertification programs

before granting credit. It also provides guidelines for these training programs.

Missouri has reciprocal relationships with several states, as listed in Table 6.7. These agreements enable out-of-state applicants to apply for a license without having to pass Missouri's certification examinations.

Table 6.7 - States Having Reciprocal Relationships With Missouri

State	Type of Agreement
Agricultural Aviation Board of Mississippi	Categories 1A, 2, 5, and 6
Arkansas	All categories except for ornamental, turf pest control, and structural pest control categories
Illinois	All categories administered by the Illinois Department of Agriculture (no agreement with the Illinois Department of Public Health)
Iowa	All categories
Kansas	All categories
Louisiana	All categories except for the structural pest control categories
Nebraska	All categories

Summary

Pesticides are valuable tools for protecting crops from insects, weeds, and other pests. However, because they are made from powerful combinations of chemicals, pesticides must be used wisely. This requires paying careful attention to all instructions and information on the label, observing signal words, following all safety precautions, and understanding how to administer first aid if needed. In the state of Missouri, only certified persons may apply pesticides. Specific procedures and examinations are required to earn certification. Several states have a reciprocal agreement with Missouri's Bureau of Pesticide Control, as cited in Missouri's regulations.

“Pest Management - Pesticides - Certified Applicator and Operators.” <<http://www.mda.state.mo.us/d7c.htm>>accessed 3/11/02.

“The Worker Protection Standard for Agricultural Pesticides - How to Comply.” EPA Publication 735-B-93-001. <<http://www/cdc.gov/niosh/nasd/docs/ep00200.htm>> accessed 5/15/02.

Credits

Acquaah, George. *Horticulture: Principles and Practices*. Upper Saddle River, NJ: Prentice Hall, 1999.

Cooper, Elmer L. *Agriscience: Fundamentals & Applications*, 2nd ed. Albany, NY: Delmar Publishers, 1995.

Fishel, Fred. “Integrated Pest Management in Missouri's Urban Environment” Integrated Pest Management - MU Guide. University of Missouri-Columbia Extension. <<http://muextension.missouri.edu/xplor/agguides/pests/ipm1004.htm>> accessed 2/21/02.

Greenhouse Operation and Management (Student Reference). University of Missouri-Columbia: Instructional Materials Laboratory, 1990.

Lee, Jasper S., Series Editor. *Introduction to Horticulture*, 3rd ed. Danville, IL: Interstate Publishers, Inc., 2000.

Nelson, Paul V. *Greenhouse Operation and Management*, 3rd ed. Reston, VA: Reston Publishing Company, Inc., 1985.

Unit VII: Greenhouse Business Management

Lesson 1: Commercial Greenhouse Crops

This unit explains why planning a commercial greenhouse crop and developing a marketing plan are essential to greenhouse business management. Lesson 1 begins with an exploration of why specific crops are selected for production, justifies why a growing schedule is important, and summarizes the costs of producing crops. Next, the lesson explains how crops are evaluated and cared for after harvest and during marketing.

Selecting Commercial Crops

One of a greenhouse owner's most important responsibilities is selecting commercial crops that can increase profits. This decision is derived from the results of a market analysis that identifies the types of plants that customers want to purchase. (Lesson 2 describes how market research is conducted.) Visiting retail and wholesale operations, local nurseries, and landscaping outlets gives the owner a sense of what is popular. Profitability is a key concern. If a plant costs too much to produce (or if it is available elsewhere for less), the greenhouse owner probably would not select it.

Another way to discern the types, sizes, and amounts of plants the public wants is to read trade journals such as *Greenhouse Manager*, *Greenhouse Grower*, and *Grower Talks* and popular magazines (e.g., *Midwest Living*, *Better Homes and Gardens*, and *House Beautiful*). The greenhouse owner must also consider whether the staff can perform specific propagation techniques required for a new crop.

University Extension offices, state and federal agricultural agencies, and Internet sites provide data that can help the greenhouse owner determine which crops to grow.

Table 7.1 displays the wholesale value of Missouri crops that grossed \$100,000 or more in 1999. Each of these crops is discussed below.

Table 7.1 - Missouri's Commercial Floriculture Crops

Crop	Wholesale Value	Percent of Total
Cut Flowers	\$ 281,000	0.8
Foliage Plants	2,192,000	6.4
Potted Flowering Plants	11,711,000	34.2
Bedding and Garden Plants	20,085,000	58.6
TOTAL	\$34,269,000	100%

Even though cut flowers represent the lowest percent of total sales, many retailers sell them in floral shops, malls, and grocery stores. The public frequently buys cut flowers for special occasions, such as roses on Valentine's Day, or just to brighten a room. In Missouri, the favorite cut flowers on the market are chrysanthemums, daffodils, gladioli, iris, narcissus, roses, snapdragons, tulips, and zinnias.

A greenhouse owner may choose to grow foliage plants because numerous species and cultivars are available, many of which are produced year-round. Potted foliage and foliar hanging baskets are the most popular in Missouri.

Some potted flowering plants, such as poinsettias and Easter lilies, are cultivated for special times of the year. Missouri greenhouse owners also raise African violets, azaleas, chrysanthemums, cyclamens, and kalanchoes. Some these potted plants are produced throughout the year.

In Missouri, bedding and garden plants have the greatest sales potential, capturing nearly 59% of

Greenhouse Operation and Management

the total floriculture market in 1999. They are used for personal and commercial landscaping projects and are available for spring sales; some are sold during summer and fall. All-time favorites in Missouri include geraniums, hardy/garden chrysanthemums, impatiens (also New Guinea impatiens), petunias, and vegetable flats.

Determining Growing Schedule

Once the commercial crops are selected, the greenhouse owner develops a growing schedule to expedite production. It identifies when to plant each crop and perform cultural practices such as fertilization, irrigation, application of pesticides, and propagation. Aeration, drainage, day-length treatment, and date of harvest are noted as well. Postharvest procedures are also cited. Referring to cultural records enables the greenhouse owner to reproduce successful crops because potential problems are isolated before they have the chance to intensify and threaten the crops.

The growing schedule reflects when to check environmental conditions, namely, temperature, amount of light exposure, and moisture and humidity levels. Other pertinent conditions noted on the schedule include the types of growing media used, nutrient and foliar analysis, and an indication of whether diseases and pests are evident on the crops. Tracking these factors helps the greenhouse owner assess production costs, recognize nutritional deficiencies, and maintain healthy plants.

Management practices are also listed, such as dates for ordering/reordering supplies, shipping, and billing.

An important feature of a growing schedule is a crop rotation plan that helps organize the allocation of bench space throughout the year. An efficiently run greenhouse optimizes the number of planting benches and the space between plants. By knowing how much production time and space

a crop requires for growth, the owner can maximize the planting cycles in the greenhouse and gain higher yields and profit. Plants should be spaced very close together when they are first transplanted, and then as they develop, they need more room between the pots. A crop rotation plan can also calculate the production time and space required per crop (as measured in square feet weeks).

- Determine how many square inches there are per flat. (Multiply the dimensions of the flat.)
- Convert square inches to square feet by dividing the total number of square inches in the flat by 144 (the total number of square inches per square foot). The result is the amount of bench space per flat in square feet.
- Multiply the amount of bench space in square feet by the number of weeks required to grow the plant.
- The result is the amount of bench space required as measured in square foot weeks.

Here's an example: A coleus flat is 12 x 24 in. and it takes 6 weeks to grow.

- (1) 12 in. X 24 in. = 288 sq in.
- (2) Convert square inches into square feet. (1 sq ft = 12 X 12 in. [144 sq in.])
- (3) Divide the total number of square inches in the coleus flat by 144 sq in. (1 sq ft)
- (4) $288/144 = 2$ sq ft (amount of bench space per flat)
- (5) 2 sq ft X 6 weeks = 12 sq ft weeks (amount of bench space required in square foot weeks)

Finally, the growing schedule names the person who is responsible for performing each task and notes when the task is completed. This provides

accountability and quality control for crop production.

Analyzing Expenses

All commercial enterprises incur two types of expenses: fixed and variable. Fixed (ownership) costs are paid regularly, regardless of the amount of sales. The major categories of fixed costs are depreciation, interest, repairs and shelter, taxes, and insurance. Applied specifically to greenhouse operations, fixed costs include the depreciation of greenhouse structures and equipment; interest on the land and building(s); repair expenses to maintain greenhouse structures, equipment, etc.; taxes on property; and insurance for employees and the greenhouse operation.

Variable (operating) costs change according to production level and amount of use. The major categories include labor (salaries), fertilizer, chemicals, seed, gasoline and oil, inventory, supplies, advertising, utilities, telephone, principal payment. When operating a greenhouse business, variable costs include labor (seasonal and full-time employees); fertilizer, rooting and growing media, and chemicals; seeds and plants; fuel for heating the greenhouse; inventory of growing and packing supplies (media, containers, and labels); advertising and display expenses; utilities, water, and telephone.

A cost analysis calculates the profit and loss of the operation and indicates the net return. A cost analysis statement records the amount of all variable expenses (designated directly to a specific crop) and the income received from all crops. For fixed expenses, a cost analysis provides the average weekly cost per square foot of bench space (including used and vacant benches). The formula is as follows:

Total fixed costs/52 (number of weeks per year)/sq ft bench space = average cost per week per square foot

For example, if the operation's total fixed costs are \$15,000 and the total bench space is 20,000 sq ft, here is how to calculate the cost:

$$(1) \$15,000/52 = \$288.46 \text{ per week}$$

$$(2) \$288.46/20,000 \text{ sq ft} = \$0.014 \text{ per week per square foot}$$

Evaluating the Commercial Crop

The greenhouse owner evaluates the quality of commercial crops before selling them to customers. Every plant must display adequate nutrients and fertilization for optimal growth and have sufficient water, aeration, and drainage.

Plants should have no yellow, broken, or dying leaves and must be free of insect damage. To appeal to customers, each container must be neat and clean and include a tag that describes how to care for the plant at home. Finally, potted plants are usually wrapped in attractive foil and displayed in a convenient location.

Caring for Commercial Plants After Harvest and During Marketing

After harvest, commercial crops require special care to ensure their ability to withstand stress and survive longer. Maintaining moisture is essential. The relative humidity must be kept at optimal levels. To offset water depletion during refrigeration, the storage area must be humidified. Keeping harvested plants away from direct heat and sunlight also protects them from moisture loss. Excessive heat harms the roots and leaves and dries out the growing media.

Regulating the respiration rate affects how well plants survive after harvest and during shipping. As the plants' food supply diminishes during respiration, crops deteriorate. Because high temperatures raise respiration, plants must be kept cool to reduce respiration, inhibit wilting, slow down metabolism, and hinder growth of mold and

Greenhouse Operation and Management

bacteria. Cool temperatures also lessen the production of ethylene, which is a gas that hastens ripening. Air circulation lowers temperature and reduces ethylene concentration.

To stay fresh, cut flowers must build up their strength with enough carbohydrates. The greenhouse owner can maintain the quality of this crop by supplying the right amount of light and cutting the plants late in the day. The “vase life” of cut flowers is compromised if the following circumstances occur: the stems are blocked and cannot absorb water, excessive moisture escapes from the flowers, or respiration is suppressed because of insufficient carbohydrates. To extend the vase life of cut flowers, several commercial preservatives are available that consist of carbohydrates, bactericide, and an acidifier. The salesperson usually attaches a complimentary package of the floral preservative when a customer purchases a bouquet of cut flowers.

Foliage, potted flowering plants, and bedding and garden plants also need sufficient amounts of carbohydrates to sustain their strength. To increase plants’ shelf life, the greenhouse owner lowers the temperature, reduces the amount of water, and decreases the amount of nutrients. Green plants receive less light. These procedures “harden” the plants, enabling them to adjust to new environments outside the protection of the greenhouse.

All crops should be handled gently and not touched more than necessary. Putting plants in protective containers with the appropriate amount of growing media keeps them secure. When loading plants onto trucks/vans for shipping, they should be secured in boxes and pallets.

During marketing, the storage and display areas should be kept cool. Every plant has a specific temperature at which its foliage, size, and overall condition remain optimal. But for every 18°F increase above that temperature, quality deteriorates. Plants also need the correct amount

of light and shade. If bedding plants are kept out of direct sun, the flowers maintain color and moisture is maintained. Only very small amounts of fertilizer are needed, if any. Watering is required only when crops exhibit stress. Placing plants on benches promotes air circulation, keeps them dry, and prevents soilborne diseases. And customers appreciate having easy access to elevated plants. Finally, a clean marketing area is not only conducive to pleasant shopping, it also limits ethylene production that results from decaying plants.

Summary

Planning a commercial crop begins with the selection of plants that will attract customers and promote sales. The greenhouse owner considers the sales potential of cut flowers, foliage, potted flowering plants, and bedding/garden plants. Once the selection process is complete, a growing schedule establishes when various cultural, environmental, and management practices should occur. The greenhouse owner must consider fixed and variable costs and prepare a cost analysis to determine the profit and loss of the operation. After the commercial crop is harvested, the owner evaluates the quality of each plant. Plants need special care after harvest and during marketing.

Credits

Ball, Vic, Editor. *Ball Red Book Greenhouse Growing*, 14th ed., Reston, VA: Reston Publishing Company, Inc., 1985.

Biernbaum, John A. “Greenhouse Crop Production: Counting the Costs and Making Cents.” Michigan State University. <http://www.hrt.msu.edu/HortLinks/pdf_files/Production_Costs_Article.pdf> accessed 3/19/02.

“Greenhouse Management - Postproduction Quality.” <<http://www.sfasu.edu/ag/horticulture/hrt321/14.%20HRT%20321%20Post%20Production%20Quality.htm>> accessed 1/4/02.

Greenhouse Operation and Management (Student Reference). University of Missouri-Columbia: Instructional Materials Laboratory, 1990.

“Greenhouse Production.” West Virginia University Extension Service. Adapted from Fact Sheet 593, University of Maryland, Cooperative Extensive Service. <<http://www.wvu.edu/~agexten/hortcult/greenhou/gnhssite.htm>> accessed 3/15/02.

Kessler, J.R. “Growing and Marketing Bedding Plants.” Alabama Cooperative Extension System. ANR-559, Revised Aug. 1999. <<http://www.aces.edu/department/extcomm/publications/anr/anr-559/anr-559.html>> accessed 12/21/01.

Kessler, J.R. “Starting a Greenhouse Business.” Alabama Cooperative Extension System. ANR-691, Revised Oct. 1999. <<http://www.aces.edu/department/extcomm/publications/anr/anr-691/anr-691.html>> accessed 3/22/02.

Lee, Jasper S., Series Editor. *Introduction to Horticulture*, 3rd ed., Danville, IL: Interstate Publishers, Inc., 2000.

“Missouri Fruit and Vegetable Growers Database Listing - Growers in Missouri.” University of Missouri Outreach & Extension. <<http://agebb.missouri.edu/hortgrow/searchre.asp>> accessed 3/14/02.

Nelson, Kenneth S. *Greenhouse Management for Flower and Plant Production*. Danville, IL: The Interstate Printers & Publishers, Inc., 1980.

Smith, Tina. “Caring for Plants in the Retail Setting.” University of Massachusetts Extension - Floriculture. <http://www.umass.edu/umext/programs/agro/floriculture/floral_facts/retail.htm> accessed 3/15/02.

Thomas Paul A. and William A. Thomas. “Starting a Greenhouse Business.” The University of Georgia College of Agricultural and Environmental Sciences Cooperative Extension Service. <<http://www.ces.uga.edu/pubcd/b1134-w.html>> accessed 3/14/02.

Wilson, L.G. et al. “Postharvest Handling and Cooling of Fresh Fruits, Vegetables, and Flowers for Small Farms. Part I: Quality Maintenance.” North Carolina A&T State University Cooperative Extension. Horticulture Information Leaflet 800. <<http://www.ces.ncsu.edu/depts/hort/hil/pdf/hil-800.pdf>> accessed 3/20/02.

Wilson, L.G. et al. “Postharvest Handling and Cooling of Fresh Fruits, Vegetables, and Flowers for Small Farms. Part II: Cooling.” North Carolina A&T State University Cooperative Extension. Horticulture Information Leaflet 801. <<http://www.ces.ncsu.edu/depts/hort/hil/pdf/hil-801.pdf>> accessed 3/20/02.

Wilson, L.G. et al. “Postharvest Handling and Cooling of Fresh Fruits, Vegetables, and Flowers for Small Farms. Part III: Handling.” North Carolina A&T State University Cooperative Extension. Horticulture Information Leaflet 802. <<http://www.ces.ncsu.edu/depts/hort/hil/pdf/hil-802.pdf>> accessed 3/20/02.

Wilson, L.G. et al. “Postharvest Handling and Cooling of Fresh Fruits, Vegetables, and Flowers for Small Farms. Part IV: Mixed Loads.” North Carolina A&T State University Cooperative Extension. Horticulture Information Leaflet 803. <<http://www.ces.ncsu.edu/depts/hort/hil/pdf/hil-803.pdf>> accessed 3/20/02.

Unit VII: Greenhouse Business Management

Lesson 2: Marketing Plan

After planning a commercial crop, the greenhouse owner must then devise a marketing strategy that promotes the merchandise. This lesson addresses three fundamental aspects of marketing: identifying customers, attracting their interest, and keeping records.

Identifying Customers

Defining the customer base depends on whether the greenhouse owner is selling to wholesale or retail customers. Wholesalers sell in bulk directly to businesses that sell the crops to other enterprises. The clientele consists of landscapers, nurseries, vegetable growers, florists, garden centers, chain stores, grocery stores, etc. They do not rely on the greenhouse wholesaler's sales personnel for advice, are not influenced by displays or advertising, and do not need customer parking lots. Each wholesaler has a small number of customers that usually purchases an entire crop all at once. Assorted crops and supplies are also bought yearlong.

Retailers sell relatively small amounts of plants to the general public in shopping areas, grocery stores, floral shops, malls, etc. These buyers may be tempted to purchase greenhouse plants from discounted wholesale outlets, which concerns retailers. Retail customers pay more per crop than wholesale clients. But retailers cater to shoppers by providing special services: informed sales personnel, attractive displays, and convenient parking lots (which cost retailers money). Patrons enjoy browsing throughout the greenhouse, so retailers have to adjust bench space and the height of displays. Although this reduces the size of the production area, retailers are often rewarded with satisfied customers who are likely to return.

One of the best techniques for identifying customers is to conduct market research. The greenhouse owner pinpoints likely customers by understanding the demographics of the area: income level, population, age ranges, employment sectors and amount of unemployment, characteristics of residential areas, and characteristics of housing developments (sizes and prices of lots). This information affects crop selection, price structure, and the advertising campaign. Chambers of commerce, realtors, census reports, telephone books, university Extensions, trade associations, media consultants, and vocational/technical schools are among the reliable resources for obtaining these statistics.

Market research also involves identifying the competition. The greenhouse owner gauges whether multiple operations are sustainable and determines if similar or different products and services are offered. Visiting retail and wholesale operations, local nurseries, and landscapers not only targets competitors but also reveals their inadequacies. For example, if a rival disregards the buying habits of young, working home owners, a greenhouse owner can seize the opportunity to appeal directly to this demographic group through advertising, special services, periodic sales, and extended hours. The location of competitors affects the greenhouse owner's site and crop selections and may also influence the customer base.

Attracting Customers

As soon as potential customers are identified, the greenhouse owner must figure out how to interest them in the merchandise. Advertising is a proven technique for generating sales. Direct mail, Web sites on the Internet, and various media (television, radio, magazines, newspapers, etc.)

Greenhouse Operation and Management

suggest diverse methods for creatively promoting name recognition and supplying information about services in a visually appealing manner.

Displays in retail greenhouses attract attention if they are located within reach and are aesthetically presented. Greenhouse personnel should encourage browsing and be available to answer questions. Sales promotions for specific crops during the holidays, seasons, and special occasions also generate interest.

Competitively priced crops appeal to consumers. The owner must determine a reasonable profit margin based on what customers are willing to pay. Coupons and periodic sales stimulate commerce and draw attention to a wide range of customers.

Keeping Records

A critical element of developing a marketing plan for a greenhouse operation is maintaining up-to-date reports. A record-keeping system documents key events enumerated on the growing schedule and assists in formulating marketing decisions. The greenhouse owner (or business manager) should maintain financial records that track and categorize fixed and variable costs. Records of earned income include the following information:

- Number of plants sold
- Price per plant
- Grade of crops
- Date when each plant was sold
- Number of good, unwanted plants
- Number of poor-quality, unwanted plants
- Total all sales

Financial records are useful tools for assessing sales trends, and they enable the owner to readily detect which crops sell the most. These records also can be used to compare the amount of sales from previous time periods. This information can affect marketing strategies, crop selection, and inventory control. Various computer software

programs are used to manage financial records, such as Quicken, Excel, Microsoft, and others.

Another type of record compiles pertinent employee information, including time sheets, salaries, hiring/firing dates, etc. A record that details expenses of mechanical systems incurred in the greenhouse (e.g., irrigation, electrical, and heating) is also important. Maintaining a current inventory helps the owner know when to reorder supplies and it facilitates smooth crop production. Software programs are often used to track and order materials.

Customer records with names, addresses, phone numbers, and credit/payment history should be on file. Adding a notation concerning clients' specific requests helps the owner ensure availability of favorite plants. Based on this profile, the owner can notify designated customers about services and new crops that will interest them.

As discussed in the previous lesson, the growing schedule incorporates information relating to environmental conditions, crop rotation, and cultural practices. The purpose of a greenhouse operation's record-keeping system is to compile, organize, and display up-to-date information for personnel who are responsible for specific tasks. Records of environmental conditions indicate the temperature, nutritional level of growing media, presence of insects and diseases, overall condition of plants, and amount of light. Computer software programs are available to predict temperature and energy use and to calculate concentrations of nutrients. As growers cultivate plants, they rely on details from this report.

A record listing the crop rotation schedule ensures maximum use of bench space for increased yield. This record designates which crops to grow during the year and assigns bench space per plant.

Another important record to post in the greenhouse itemizes various cultural practices per

crop. Among the entries on this report are planting dates; amount of day-length treatment per plant; irrigation, aeration, and drainage per crop; amounts, formulations, and dates of fertilizer applications; pest control methods; and dates of harvest per crop. New computer software programs are designed to graph soil tests and insect counts and to manage pest control.

Summary

Identifying the customer base depends on whether the greenhouse owner is a wholesaler or retailer. Different consumers are available in each sector. A market research study provides demographic information about the community that guides the greenhouse owner in targeting the client base. It is equally important to know who the competition is and to assess whether the market can support multiple operations. Advertising, nicely arranged displays throughout the greenhouse, and competitive pricing are proven techniques to attract customers. A well-developed marketing plan relies on a current and thorough record-keeping system that documents information from financial and personnel reports as well as the growing schedule.

Credits

Ball, Vic, Editor. *Ball Red Book Greenhouse Growing*, 14th ed., Reston, VA: Reston Publishing Company, Inc. 1985.

“FloraSoil and FloraPest.” <<http://ceinfo.unh.edu/Agriculture/Documents/flora.htm>> accessed 3/19/02.

Greenhouse Operation and Management (Student Reference). University of Missouri-Columbia: Instructional Materials Laboratory, 1990.

“Greenhouse Software Toolkit.” Enermodal Engineering. <http://www.enermodal.com/software_toolkit.html> accessed 3/19/02.

Hall, Charles R. “Plan for Improved Marketing.” <<http://aggie-horticulture.tamu.edu/greenhouse/econ/chmkt.html>> accessed 3/19/02.

Glossary

agronomists – specialists in soil and crop sciences

amendment – any material, such as peat moss, processed bark, and sand, added to a growing medium to improve its ability to support plant growth

auxiliary bud – the bud that forms in the angle that the leaf makes with the main stem

bagasse - the plant residue from sugarcane left after the juice has been extracted; used as a nonwood fiber

binomial nomenclature – a two-part name

botanists – scientists who study plants

bulb – any underground stem consisting of layers of fleshy scales that overlap each other

capillary action – the movement of water through a growing medium because of the adhesion of water molecules to the medium

cation-exchange capacity – the ability of the growing medium to attract and hold nutrients

cellular respiration – the controlled breaking down of glucose that releases energy for plant growth, absorption, translocation, and other metabolic processes

coldframe – an unheated outdoor growing structure covered with a transparent glazing material

complete fertilizer – a fertilizer containing nitrogen, phosphorus, and potassium

condensation – moisture colder than air that is on leaves

corm – a specialized stem that is a solid, fleshy, scale-covered enlargement

creeper stems - vines that grow on the ground without additional support

cultivar – a subcategory within a species that is developed by botanists and agronomists, (not occurring in the wild); usually capitalized and written with single quotation marks or it precedes the species' name and is abbreviated as 'cv'

cuttings – a method of vegetative propagation in which plant pieces are “cut” from the parent plant and rooted to form new plants

day-neutral plant – a species that flowers regardless of the light/dark ratio

dolomitic limestone – limestone with a high magnesium content

dormancy – the resting stage of seeds

enzymes – large, complex proteins that activate chemical reactions within cells

epigeous germination – growing aboveground

evapotranspiration – the combined loss of moisture from evaporation and transpiration

fertigation – applying fertilizer through an irrigation system

floriculture – a specialty of horticulture that deals with producing, cultivating, and managing ornamental plants and flowers

fungicide – chemical pesticide directed at fungi

growing medium – a material used for growing plants; may contain peat moss, sand, perlite, soil, or other ingredients (plural: growing media)

herbicide – a chemical pesticide directed at weeds

horticulture – the cultivation, processing, and sale of fruits, nuts, vegetable, ornamental plants, and flowers

hotbed – an outdoor growing structure similar to a coldframe but heated by a source besides the sun

hydroponics – growing plants in a nutrient solution, not soil

hypogeous germination – growing underground

imperfect flower – flower that contains male or female parts, not both

incomplete flower – flower missing one or more of the main parts of the flower: sepals, petals, stamens, or pistils

infiltration – the rate of water absorption into the roots through the pores

infrared – wavelengths longer than red light

insecticide – chemical pesticide directed at insects

internodes – parts of the stem or other plant parts that are located between two nodes (regions of the stem where one or more leaves are attached)

landscape horticulture – raising ornamentals for outside use

layering – a vegetative method of propagating plants by rooting a new plant while the stem is still attached to the parent plant

leaching – washing important nutrients from the soil

long-day plant – a species that flowers only in a day length of critical duration

macronutrient – one of six essential elements needed in relatively large amounts for plant growth: nitrogen, phosphorus, potassium, calcium, magnesium, and sulfur

meristem tissue – tissues that actively divide to form new growth

micronutrient – one of eight essential nutrients needed in tiny quantities for plant growth: iron, copper, zinc, boron, molybdenum, chlorine, manganese, and cobalt

nematodes – tiny round worms that attack plant roots

nodes - swollen areas at the joints of stems where buds and leaves originate

osmosis – the movement of water across a semipermeable membrane from a higher concentration to a lower concentration

ozones – compounds found above the Earth's surface that filter out harmful ultraviolet rays

pasteurization – a process that kills harmful organisms and preserves beneficial organisms

perfect flower – a flower that has both male and female parts

permeability – the ability to transport water into the plant

pesticide – a chemical used to control an undesirable organism

petiole – the stem of a leaf

pH – a measurement of the level of alkalinity/acidity

phloem – part of the vascular system that transports carbohydrates from the photosynthesizing cells to the rest of the plant

photoperiod – the light/dark ratio in a day

photoperiodism – the influence of day length vs. night length on plant growth

photosynthesis – process by which green, living plants convert carbon dioxide and water to simple sugar in the presence of light

phototropism – a plant's bending toward the source of light

phytotoxic – poisonous to plants

pinching – removing the terminal bud of a plant to promote branching

plumule – first shoot of a developing plant; also known as the coleoptile

porosity – the pore space (tiny openings) between solid particles

propagation – plant reproduction by sexual or vegetative methods

propagation bed – a special location within the greenhouse that is used to allow cuttings to root

quality of light – the spectrum of color (wavelength) that is measured in nanometers

rhizome – an underground stem that produces roots on the lower surface and extends leaves and flowering shoots above the ground

scarification - scratching or modifying the seed coat in order to increase water absorption

scion – unrooted, upper part of plant used for grafting

seed dormancy – resting stage of the seed that prevents the seed from germinating until environmental conditions are favorable

seed germination – a process in which a seed changes into a developing seedling

short-day plant – a species that flowers only in a daily dark period of critical duration

stolon – a stem that grows horizontally above the soil surface

stomata – specialized pores in the epidermis of the leaf used to exchange gas

stratification – a rest period for seeds before germination can occur; seeds are placed in moist growing medium at 32-50°F for a certain period of time

succulents – plants with thick, fleshy leaves that store water, e.g., cacti and jade plants

taxonomy – the science of identifying, naming, and classifying plants

topography – the shape of the land, e.g., hilly, flat, steep, rocky

translocation – the movement of minerals, water, carbohydrates, and other materials within the vascular system of a plant

transpiration – the loss of water by evaporation primarily from the leaf surface through specialized pores called “stomata”

tuber – a short, thick underground stem that serves primarily as a food storage area

ultraviolet – wavelengths shorter than violet light

vascular system – the system that moves carbohydrates, water, and minerals throughout the plant; includes xylem and phloem cells

viability – the ability of seeds to germinate

water-holding capacity – the ability of a growing medium to retain water

xeromorphic foliage – leaves adapted for plants that grow in arid conditions

xylem – part of the vascular system that transports water and minerals upward from the roots to the photosynthesizing cells

